

# SACE Emax 2

Emax low voltage air circuit-breakers Emax E2.2-E4.2-E6.2

Installation, operation and maintenance instructions for  
the installer and the user





- Glossary ..... 3**
  
- Emax E2.2-E4.2-E6.2 circuit-breakers..... 4**
  - 1 - Contents .....4
  - 2 - Safety .....5
  - 3 - Regulations.....6
  
- Management operations ..... 7**
  - 1 - Transport and checking on receipt.....7
  - 2 - Unpacking and handling ..... 10
  - 3 - Description ..... 13
  - 4 - Environmental conditions.....23
  - 5 - Installation ..... 23
  
- Ekip Dip..... 31**
  - 1 - General characteristics .....31
  - 2 - Operating features ..... 32
  - 3 - Operator interface.....33
  - 4 - Protections ..... 36
  - 5 - Measurements ..... 43
  - 6 - Test.....44
  - 7 - List of alarms and signals ..... 45
  - 8 - Additional functions ..... 47
  - 9 - Default parameters ..... 47
  
- Accessories ..... 48**
  - 1 - Overview.....48
  - 2 - Rating Plug ..... 49
  
- Putting into service and maintenance..... 50**
  - 1 - Putting into service .....50
  - 2 - Identification of alarms or failures ..... 54
  - 3 - Maintenance ..... 58
  - 4 - First level maintenance ..... 60
  - 5 - Second level maintenance ..... 64
  - 6 - Decommissioning and treatment at end of life .....73



# Glossary

Term	Description
SACE Emax 2	New series of ABB SACE air circuit-breakers
CB	Circuit-breaker
Trip unit	Electronic unit connected to the CB, which provides measuring, monitoring and protection functions for the CB if faulty operating conditions occur. In the event of an alarm, it commands a TRIP
Ekip Dip	Trip unit SACE Emax 2 CBs, equipped with dip-switch type interface
Trip coil	CB opening actuator controlled directly by Trip unit
TRIP	Concluding action of protection timing or a test command which, except in special configurations applicable to the trip unit, coincides with activation of the trip coil, which instantly opens the bars of each pole and interrupts the circulating current
Vaux	Auxiliary power supply
4P / 3P / 3P + N	CB configuration: four-pole (4P), three-pole (3P) and three-pole with external neutral (3P + N)
If	Fault current measured by Trip unit, useful for calculating the trip time $t_t$

# Emax E2.2-E4.2-E6.2 circuit-breakers

## 1 - Contents

**Overview** This manual contains instructions on the operations to be performed on Emax E2.2-E4.2-E6.2 circuit-breakers throughout their life cycle, from reception to installation, and from commissioning to subsequent maintenance during operation, with particular attention to the environment at the end of the life cycle of the product.

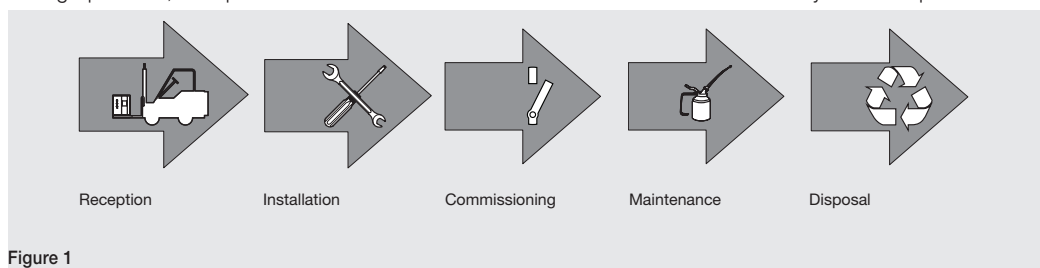

**Integrated informations** A full description of Emax 2 circuit-breakers is available in document [1SDH001330R1002](#) (Emax 2 engineering manual) available on the website ABB library.



**!** **IMPORTANT: all codes and documents mentioned in this document refer to Emax 2 configured with Trip unit Firmware version= 3.xx.**

**If the Firmware version of the Trip unit on the Emax 2 circuit-breaker =2.xx, consult document [1SDH001330R0002](#) available on the website ABB library.**

**recipients** This manual refers to two user profiles, as defined by standard IEC 60050:

- Electrically Skilled Person (IEV 195-04-01): person with relevant education and experience to enable him or her to perceive risks and to avoid hazards which electricity can create.
- Trained Persons in the electrical field (IEV 195-04-02): person adequately advised or supervised by electrically skilled persons to enable him or her to perceive risks and to avoid danger which electricity can create.

**!** **IMPORTANT: This manual specifically indicates what operations can be performed by people trained in the field of electricity. All the remaining operations described in the handbook must be performed by skilled persons, in the electrical field. ABB declines all liability for damage to persons or property caused by failure to comply with the instructions in this document.**

**Specifications and supporting documents** To ensure that the Emax 2 circuit-breaker is installed and configured correctly, please read the information in this manual and in the technical documentation of the product, supplied with the circuit-breaker or available in the website [ABB LIBRARY](#)

Document	Description
1SDH001330R1002	Manual for design engineers with full information about the trip units and accessories for Emax 2
1SDH001316R1002	Manual of Ekip Touch trip units for Emax 2 circuit-breakers
1SDC200023D0906	Sace Emax 2 CBs General catalog
1SDM000091R0001	Sace Emax 2 CBs Circuit diagrams
1SDH001140R0001	Communication System Interface for Emax 2 CBs

**Design notes** The information in this manual was written in Italian and then translated into other languages to conform to the laws and/or commercial requirements concerning the product.

## 2 - Safety

### Warnings



Figure 2

The following warnings must be respected:

- **READ THE INSTRUCTIONS CAREFULLY BEFORE TRYING TO INSTALL, OPERATE OR REPAIR THE CIRCUIT BREAKER.**
- Store these instructions along with other documents for instruction, maintenance and installation, drawings and descriptive notes on the circuit-breaker.
- Keep these documents available during the installation, operation and maintenance of the appliance. The use of these instructions facilitates proper maintenance.
- Install the circuit-breaker within the limits of the project described in the instruction manual shipped with the unit. These circuit-breakers are designed to operate with values of voltage and current within the limits of plate ratings. Do not install this equipment in systems operating at nominal values exceeding these limits.
- Follow the safety procedures indicated by Your Company.
- Do not open any covers or doors, do not work on devices before removing power from all circuits, and after making sure of that with a measuring instrument.



### WARNING!

- detailed descriptions of standard procedures for installation, use, maintenance and principles for safe operation are not included. It is important to note that this document contains safety and precaution instructions, against certain methods (of installation, use and maintenance) that could cause harm to personnel, damage devices, or make them unsafe.
- these warnings and alarms do not include all conceivable ways to make installation, use and maintenance recommended by ABB or not, that may be made, or possible consequences and complications of each conceivable way, nor shall ABB investigate all those ways.
- anyone using maintenance procedures or devices, recommended by ABB or not, must check thoroughly that neither personal safety nor the safety devices are endangered by mode of installation, use, maintenance or the instruments used. For more information, questions or specific problems contact your nearest ABB representative.
- This manual is written for qualified personnel only and is not intended as a substitute for a proper course, or experience about safety procedures for this device.
- for the products equipped with communication, the purchaser, the installer or the final customer is responsible for applying all the IT safety measures necessary in order to prevent risks deriving from connection to communication networks; such risks include, among other things, the use of the product by unauthorized persons, alteration of its normal functionality, accessing and modifying the information.
- the purchaser, installer or end user is responsible for ensuring that notices and safety signs are posted and that all access points and switching devices are locked securely when the switchgear is left unattended, even momentarily.
- all the information contained in this document reflects the latest product information available at the time of printing. We reserve the right to edit the document at any time and without notice

---

## 3 - Regulations

---

**Standards** The SACE Emax 2 circuit-breakers and their accessories comply with the following international standards:

- IEC 60947
- EN 60947
- CEI EN 60947
- IEC 61000
- UL 1066

They comply with the following EC directives:

- "Low Voltage Directives" (LVD) no.. 2006/95/EC
- "Electromagnetic Compatibility Directive" (EMC) no. 2004/108/EC

The SACE Emax 2 circuit-breakers also feature a range certified according to these standards:

- Russian - GOST (Russia Certificate of Conformity)
  - Chinese - China CCC (China Compulsory Certification)
-



# Management operations

## 1 - Transport and checking on receipt

**Introduction** The SACE Emax 2 circuit-breakers, on account of their weight, require special attention during transport and handling.

They are distributed with following packages:

- single package for fixed circuit-breaker
- two packages for withdrawable circuit-breakers (one package for the fixed part and one for the mobile part).



**WARNING! comply with the following instructions during each transport phase:**

- **The movable part of the circuit-breaker must be removed from the switchgear and/or from the relative fixed part even if this latter is not installed in the switchgear.**
- **The circuit-breaker must be in the open position.**
- **The circuit-breaker must be protected and fastened in its original packing.**
- **The closing springs of the circuit-breaker must be completely discharged.**

### Weight of the circuit-breakers with packaging

The following table specifies the weights of the circuit-breakers with packaging:

	Fixed			Moving part of withdrawable device			Fixed part of withdrawable device		
	III	IV	Fs	III	IV	Fs	III	IV	Fs
E2.2	46 Kg / 101 lbs	58 Kg / 128 lbs		53 Kg / 117 lbs	60 Kg / 132 lbs		41 Kg / 90 lbs	49 Kg / 108 lbs	
E4.2	63 Kg / 139 lbs	77 Kg / 170 lbs		67 Kg / 148 lbs	81 Kg / 179 lbs		57 Kg / 126 lbs	69 Kg / 152 lbs	
E6.2	118 Kg / 260 lbs	134 Kg / 295 lbs	151 Kg / 333 lbs	129 Kg / 258 lbs	143 Kg / 315 lbs	159 Kg / 350 lbs	96 Kg / 212 lbs	109 Kg / 240 lbs	123 Kg / 271 lbs
E2.2-A	50 Kg / 110 lbs	63 Kg / 139 lbs		59 Kg / 130 lbs	68 Kg / 150 lbs		39 Kg / 86 lbs	46 Kg / 101 lbs	
E4.2-A	66 Kg / 154 lbs	81 Kg / 179 lbs		75 Kg / 165 lbs	91 Kg / 201 lbs		52 Kg / 115 lbs	63 Kg / 139 lbs	
E6.2-A	126 Kg / 278 lbs	143 Kg / 315 lbs	159 Kg / 351 lbs	147 Kg / 324 lbs	163 Kg / 359 lbs	180 Kg / 397 lbs	88 Kg / 194 lbs	100 Kg / 220 lbs	110 Kg / 243 lbs



### NOTE:

- *weights are indicated with reference to the basic circuit-breakers including protection trip unit and its sensors, without terminals and without accessories.*
- *the weights of the fixed part of withdrawable circuit-breakers refer to the version with horizontal rear terminals.*

### Transport of the packaged circuit-breaker

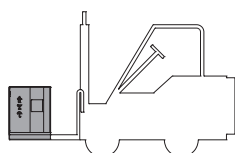

Consult the table "Weight of the circuit-breakers with packaging" before proceeding with the transport.



**WARNING! Improper lifting can result in death, serious injury to persons and damage to the equipment. Never lift a circuit-breaker and / or a fixed part above other people.**



**IMPORTANT: The trained personnel in charge of handling and lifting must use appropriate safety equipment.**

**Identification of packaging** Examine the state of the packaging and check that:

- The data on the packaging plate match the data of the order.
- The box is intact and perfectly closed.

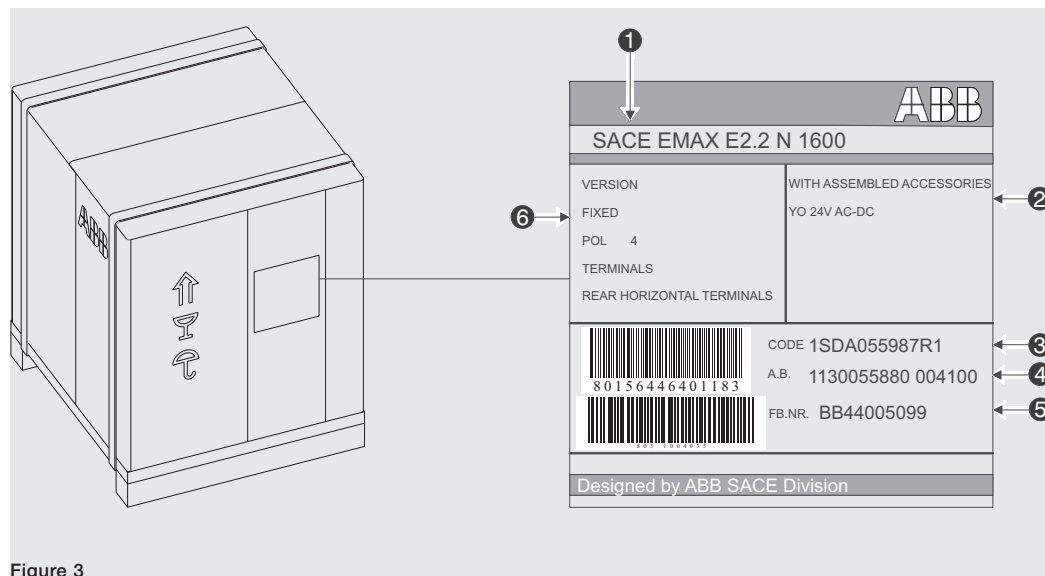

Figure 3

Pos.	Description
1	Short description of the circuit-breaker
2	Description of accessories
3	Commercial code
4	Confirmation number and location
5	Circuit-breaker serial number
6	Features of the circuit-breaker

**Packaging checks** Examine the state of the material received and verify that:

- The circuit-breaker or the fixed part are consistent with the order.
- The circuit-breaker or the fixed part are completely intact.

**IMPORTANT:**

- **If the material is to be stored, check it beforehand. For opening the packaging, follow the procedures outlined in the section "Unpacking and handling - opening the packages" on page 10**
- **In the case of any inconsistencies, report them within five days of reception. See the paragraph "Damage and Discrepancy Report" in this chapter.**

**Damage and Discrepancy Report**

If there is any damage to the packaging upon receipt and / or inconsistencies between order and product identification label or product please contact ABB. Damage to the packaging must be reported no later than seven days from receipt of the material.



**NOTE:** The notification must indicate the Packing List number.

**Storage method** Place the packaging (circuit-breakers and / or fixed parts) on a horizontal plane, not in contact with the floor. If the circuit-breaker has been removed and reinserted in the package ensure, prior to storage that:

- The circuit-breaker is in the open position and the springs are discharged. See the chapter "Description - circuit-breaker opening/closing operations" on page 16
- The circuit-breaker is protected and locked in its original packaging



**WARNING!** up to three E2.2 and E4.2 circuit-breaker packages and up to two E6.2 circuit-breaker packages can be stacked. If the packaging has been opened, you can stack the circuit-breakers on condition that the package is re-wrapped as the original.

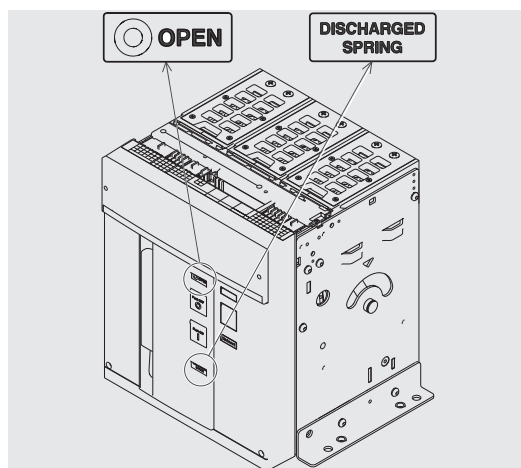

Figure 4

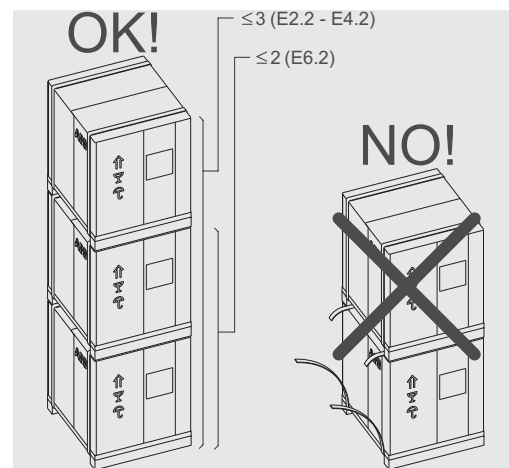

Figure 5

## 2 - Unpacking and handling

### Opening the packaging



**NOTE:** to unpack the circuit-breaker safely refer to the instruction sheet in the zipped packaging pouch.

The following is the procedure for opening the packaging:

1. Cut the bands that wrap the packing box. See Figure 6 and Figure 7.

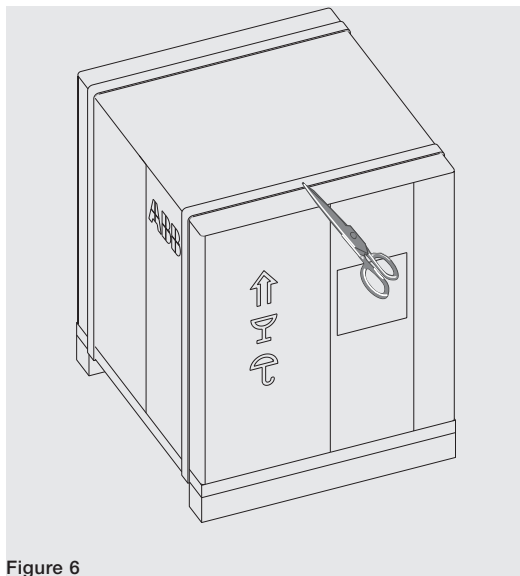

Figure 6

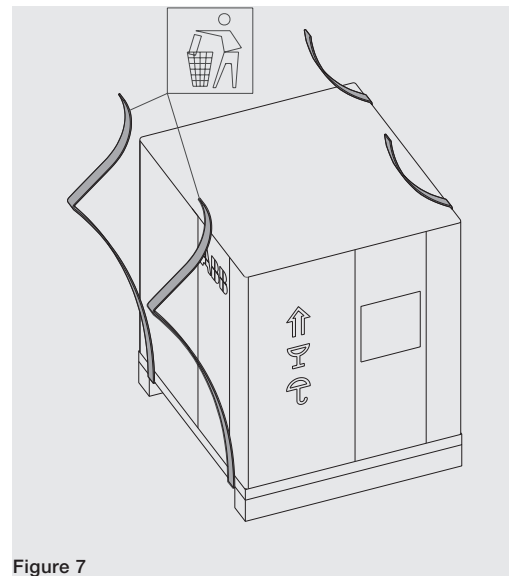

Figure 7

2. Open the upper part of the packing box. See Figure 8.
3. Remove the packing box by lifting it upwards. See Figure 9.

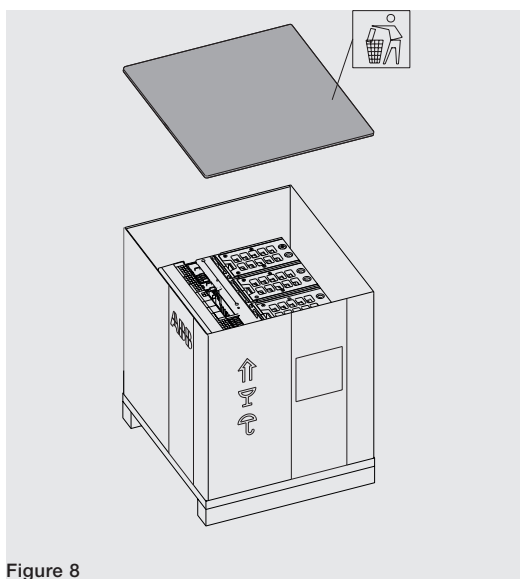

Figure 8

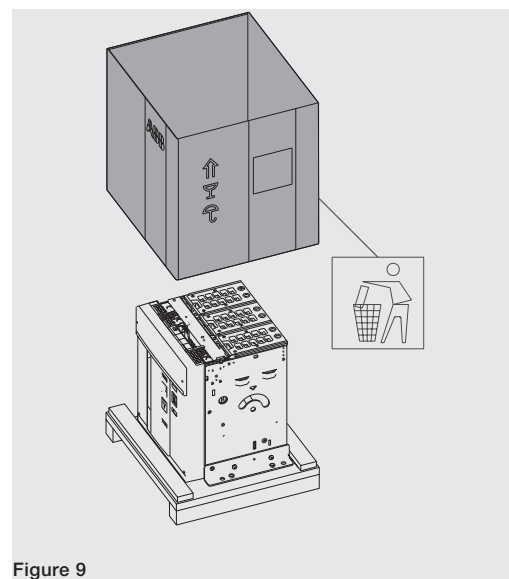

Figure 9

Continued on the next page

4. Take out the screws (See Figure 10 Fixed circuit-breaker). Take out the screws and the mounting brackets (See Figure 11 Moving part IEC, Figure 12 Moving part UL, Figure 13 Fixed part IEC and Figure 14 Fixed part UL).

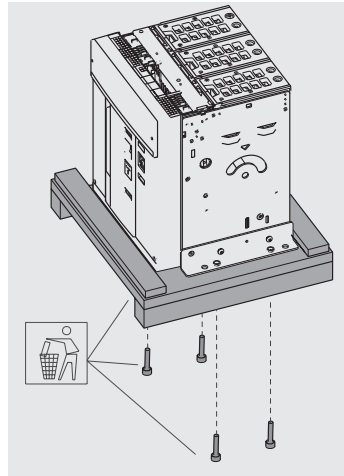

Figure 10 Fixed circuit-breaker

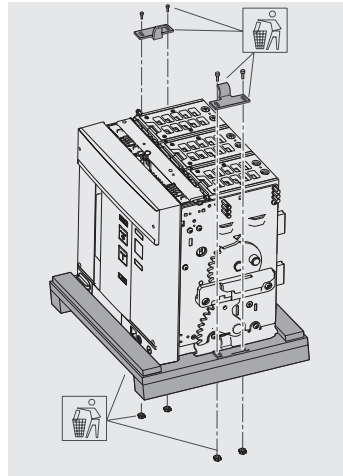

Figure 11 Moving part IEC

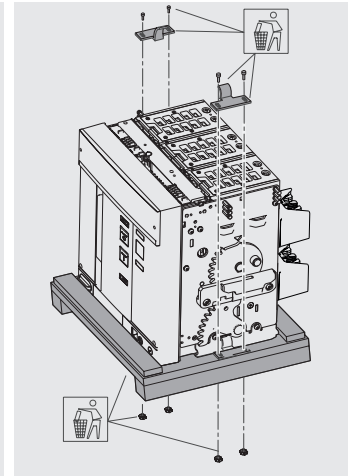

Figure 12 Moving part UL

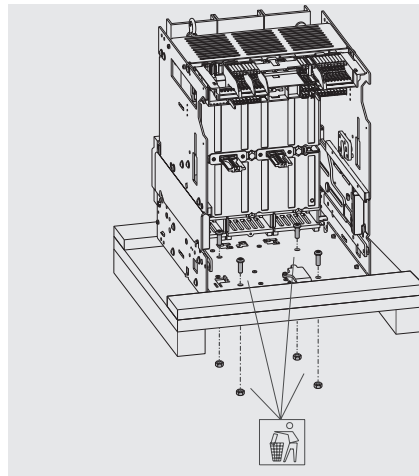

Figure 13 Fixed part IEC

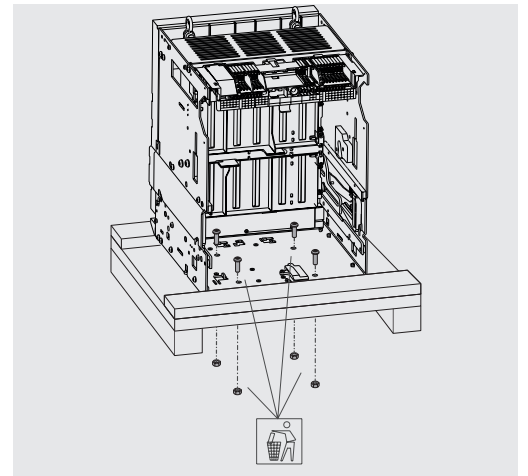

Figure 14 Fixed part UL

**Disposal of packing materials** For disposal of the packaging materials see the chapter " 6 - Decommissioning and treatment at end of life " on page 73.

## Weight of circuit-breakers without packaging

The following table specifies the weights of the circuit-breakers without packaging:

	Fixed			Moving part of withdrawable device			Fixed part of withdrawable device		
	III	IV	Fs	III	IV	Fs	III	IV	Fs
E2.2	41 Kg / 90 lbs	53 Kg / 117 lbs		48 Kg / 106 lbs	55 Kg / 121 lbs		36 Kg / 79 lbs	44 Kg / 97 lbs	
E4.2	56 Kg / 123 lbs	70 Kg / 154 lbs		60 Kg / 132 lbs	74 Kg / 163 lbs		50 Kg / 110 lbs	62 Kg / 137 lbs	
E6.2	109 Kg / 240 lbs	125 Kg / 276 lbs	140 Kg / 309 lbs	120 Kg / 265 lbs	134 Kg / 295 lbs	148 Kg / 326 lbs	87 Kg / 192 lbs	100 Kg / 220 lbs	112 Kg / 247 lbs
E2.2-A	45 Kg / 99 lbs	58 Kg / 128 lbs		54 Kg / 119 lbs	63 Kg / 139 lbs		34 Kg / 75 lbs	41 Kg / 90 lbs	
E4.2-A	59 Kg / 130 lbs	74 Kg / 163 lbs		68 Kg / 150 lbs	84 Kg / 185 lbs		45 Kg / 99 lbs	56 Kg / 123 lbs	
E6.2-A	115 Kg / 254 lbs	132 Kg / 291 lbs	148 Kg / 326 lbs	136 Kg / 300 lbs	152 Kg / 335 lbs	169 Kg / 373 lbs	77 Kg / 170 lbs	89 Kg / 196 lbs	99 Kg / 218 lbs



### NOTE:

- the weights indicated in the table refer to the basic circuit-breakers including relays and its sensors, without terminals and without accessories.
- the weights of the withdrawable circuit-breakers refer to the weight of the fixed part in a version with horizontal rear terminals.

Lift the fixed circuit breaker or the moving part of a withdrawable circuit-breaker



**WARNING! Improper lifting can result in death, serious injury to persons and damage to the equipment. Never lift a circuit-breaker and / or a fixed part above other people.**



**IMPORTANT: The trained personnel in charge of handling and lifting must use appropriate safety equipment.**

To lift the circuit-breaker:

1. Raise the circuit-breaker from the base of the packaging with the aid of the lifting plates supplied with the circuit-breaker. See Figure 15 and Figure 16.

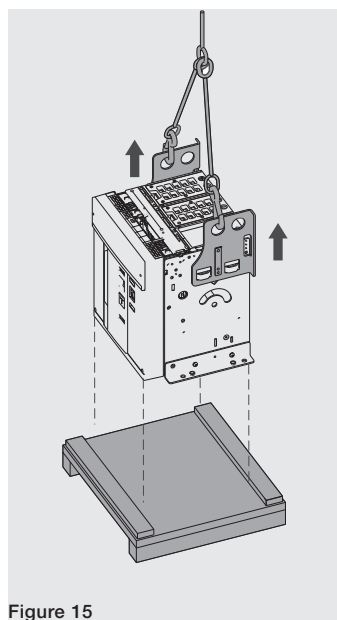

Figure 15

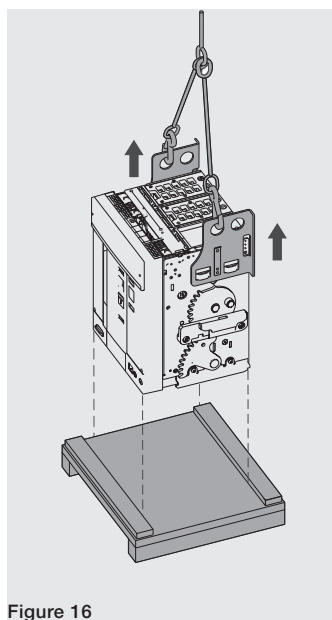

Figure 16

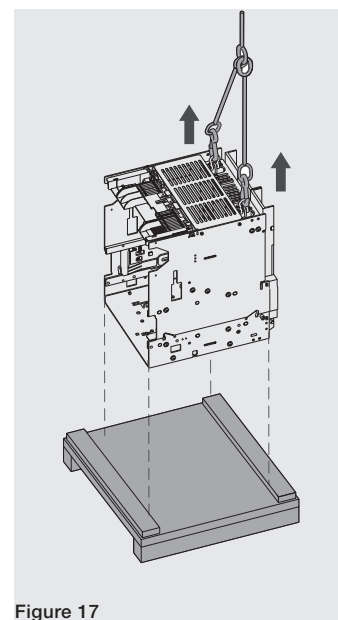

Figure 17

To raise the fixed part of the circuit-breaker

1. Raise the fixed part from the base of the packaging with the aid of the two hooks supplied with the fixed part. See Figure 17.



**IMPORTANT: keep the lifting plates for the circuit breaker, the lifting hooks of the fixed part and the manual of the circuit-breaker until disposal.**

## 3 - Description

**Description of circuit-breaker** The Emax E2.2-E4.2-E6.2 circuit-breakers consist of a steel structure in which the operating mechanism, the poles and the auxiliary parts are located.

Each pole, isolated from the others, contains the breaking parts and the current transformer of its own phase.

The structure of the poles differs between selective or current-limiting circuit-breaker.

The circuit-breaker is available in two types:

- fixed version
- withdrawable

The circuit-breaker in fixed version (see Figure 18) has its own terminals for connection to the power circuit.

The withdrawable circuit breaker consists of a mobile part (see Figure 19) and of a fixed part (see Figure 20 for IEC and Figure 21 for UL) for connection through its own terminals to the power circuit.

The coupling between the mobile part and the fixed part is via disconnection contacts mounted on the fixed part.

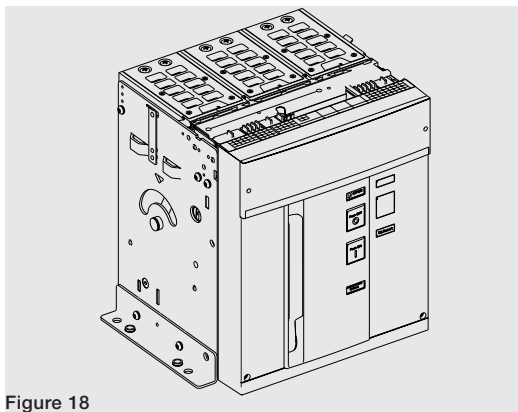

Figure 18

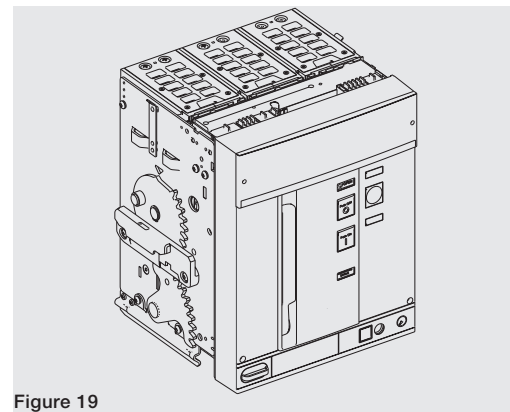

Figure 19

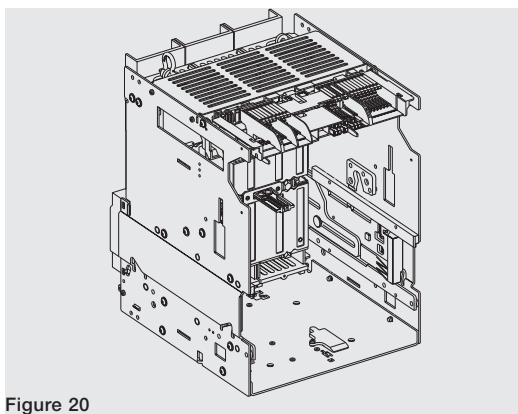

Figure 20

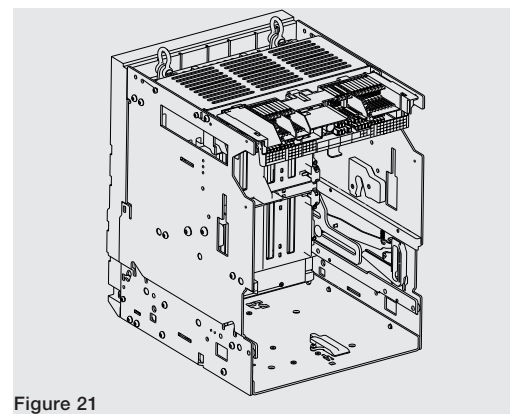

Figure 21

**Description of the circuit-breaker front panel**

The following are the main components of the circuit-breaker:

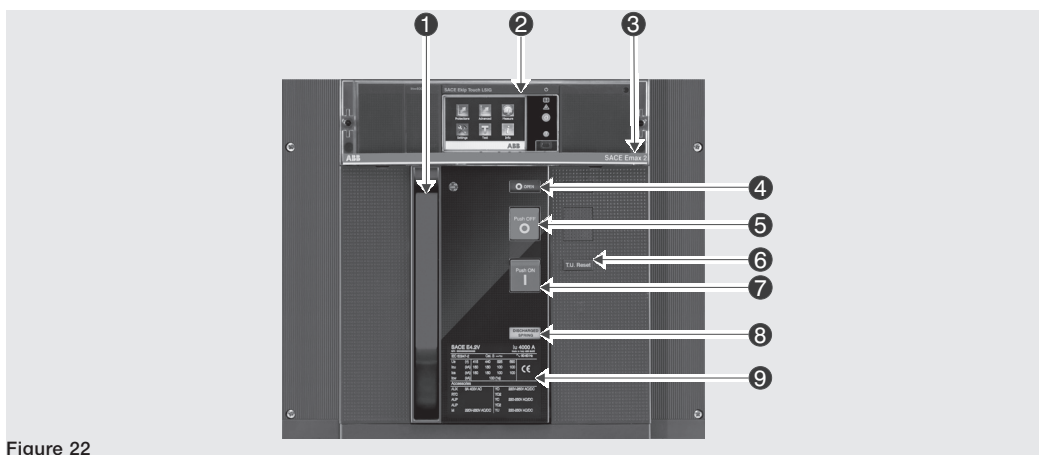

Figure 22

Pos.	Description
1	Lever for manually charging the closing springs
2	Ekip protection trip unit
3	Name of the circuit-breaker
4	CB open (O) / closed (I) indicator
5	Opening pushbutton
6	Mechanical signalling of tripped TU
7	Closing pushbutton
8	Springs charged-discharged signalling device
9	Electrical data plate

**Description of electrical data plate IEC**

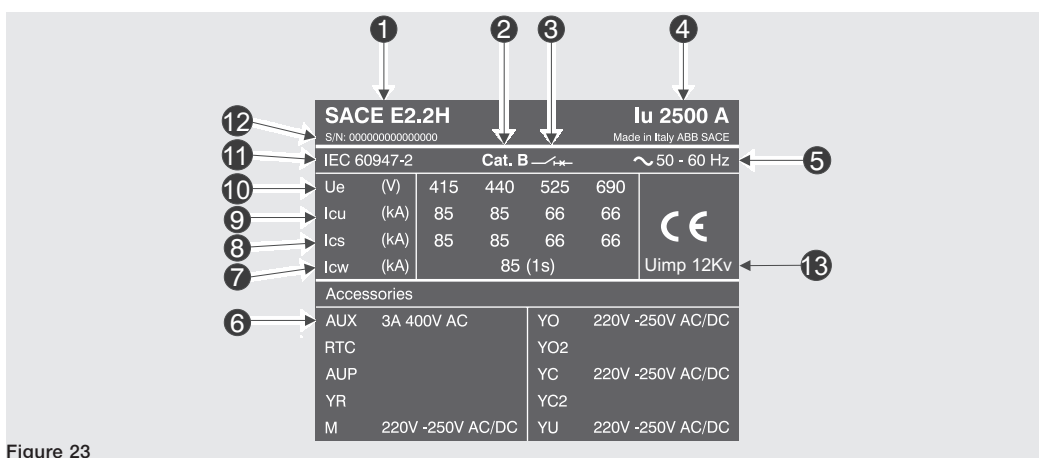

Figure 23

Pos.	Description
1	Type of circuit-breaker
2	Utilization category
3	Device type: Circuit-breaker or switch-disconnector
4	Rated current
5	Rated operating frequency
6	Rated voltage of accessories
7	Admissible rated short-time current
8	Rated duty short-circuit breaking capacity
9	Rated ultimate short-circuit breaking capacity
10	Rated service voltage
11	Standards
12	Circuit-breaker serial number
13	Impulse voltage



Description of electrical data plate UL

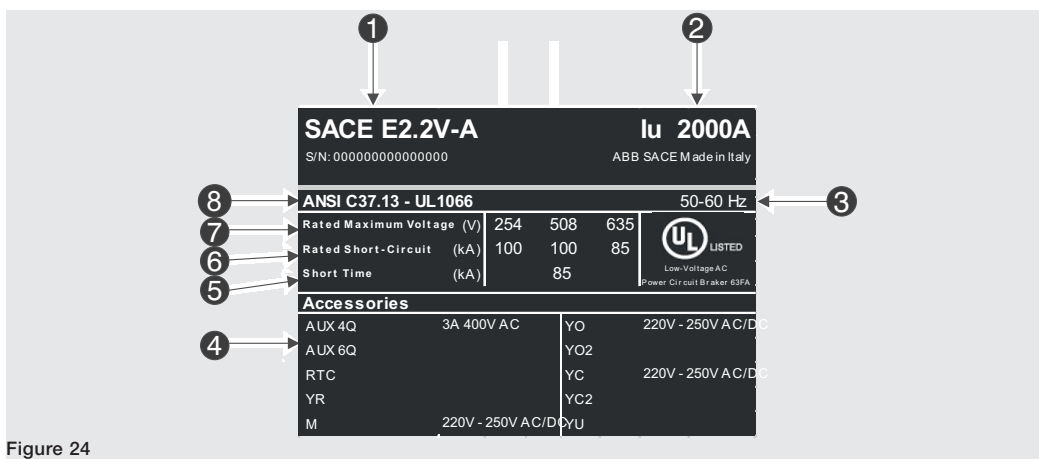

Figure 24

Pos.	Description
1	Type of circuit-breaker
2	Rated current
3	Rated operating frequency
4	Rated voltage of accessories
5	Rated short-circuit breaking capacity
6	Rated service voltage
7	Standards
8	Circuit-breaker serial number

## Manual operations for opening and closing the circuit-breaker

The following is the sequence of steps for closing and opening the circuit-breaker:

1. Check that the circuit-breaker is open (open / closed indicator "O - OPEN"), and check that the springs are discharged (spring signalling device "white - DISCHARGED SPRING") as indicated in Figure 25.
2. Charging the springs - Pull the lever [A] downwards several times until the springs charged signalling device [B] is "yellow - CHARGED SPRING" as indicated in Figure 26.

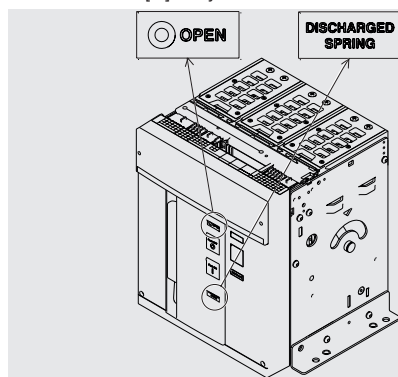

Figure 25

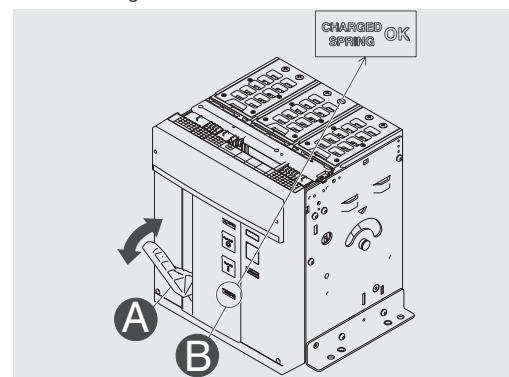

Figure 26

3. Check that the circuit-breaker is open (open/closed signalling device "O - OPEN"), and check that the springs are charged (springs signalling device "yellow - CHARGED SPRING") as indicated in Figure 27.
4. Closing - Press the closing pushbutton "I - Push ON" as indicated in Figure 28.

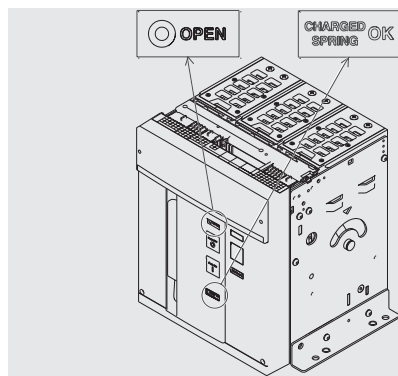

Figure 27

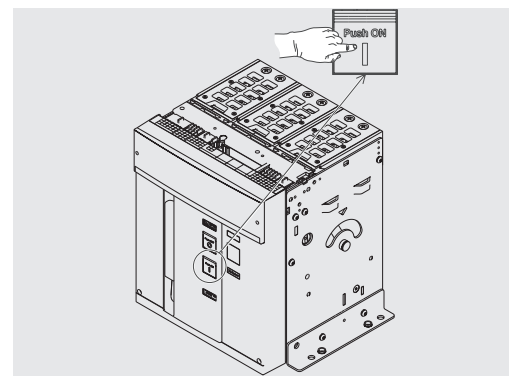

Figure 28

5. Check that the circuit-breaker is closed (open/closed indicator "I - CLOSED"), and check that the springs are discharged (spring signalling device "white - DISCHARGED SPRING") as indicated in Figure 29.
6. Opening - Press the opening pushbutton "O - Push OFF" as indicated in Figure 30.

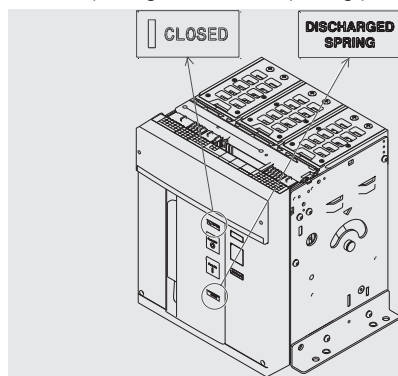

Figure 29

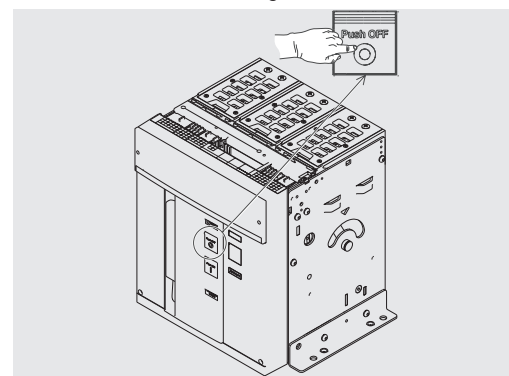

Figure 30

Continued on the next page

7. Check that the circuit-breaker is open (open / closed indicator "O - OPEN"), and check that the springs are discharged (spring signalling device "white - DISCHARGED SPRING") as indicated in Figure 31.

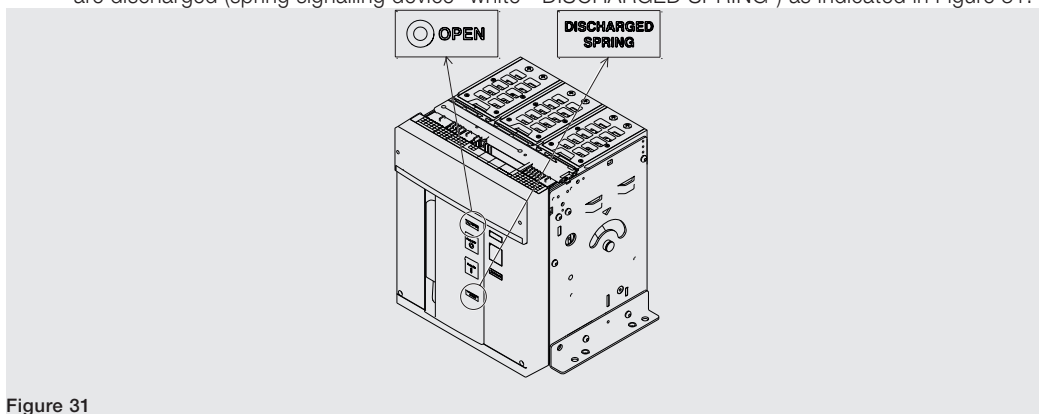

Figure 31

### Mechanical status indicators

The following are the possible states in which you can find the circuit-breaker:

1. Circuit-breaker open with springs discharged (see Figure 32).
2. Circuit-breaker open with springs charged (see Figure 33).
3. Circuit-breaker closed with springs discharged (see Figure 34).
4. Circuit-breaker closed with springs charged and not ready to close (see Figure 35). This state occurs when after closing (see step 4 - Manual operations for opening and closing the circuit-breaker) the springs are recharged manually or automatically by the gearmotor (if provided).
5. Circuit-breaker open with springs charged and not ready to close (see Figure 36). This state occurs in the following cases:
  - The circuit-breaker is open due to tripping of protection trip units and the Reset signal has not been reset. To close the circuit-breaker press the TU Reset pushbutton on the front of the circuit-breaker.
  - The key lock or padlock is active in the open position.
  - The undervoltage coil is de-energized
  - The opening coil is permanently energized.
  - The closing coil is permanently energized.
  - The pushbutton for enabling the insertion/extraction crank of a withdrawable circuit-breaker is pressed.

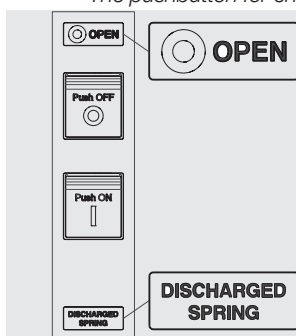

Figure 32

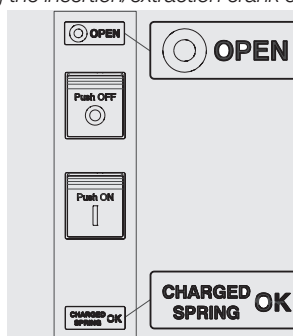

Figure 33

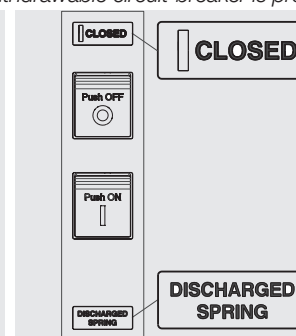

Figure 34

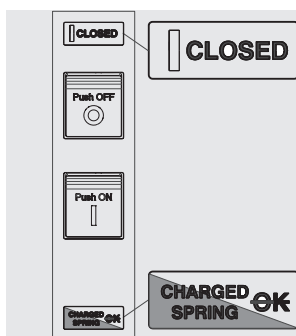

Figure 35

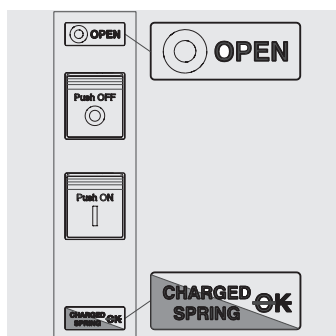

Figure 36

## Circuit breaker racking-in/ racking-out operations

The following is the procedure for the insertion of the moving part in the fixed part:



### WARNING!

- Make sure the circuit-breaker is disconnected from all sources of energy.
- Switch the circuit-breaker to the open position with springs discharged.



**WARNING! Before proceeding, remove all equipment used during the work and remove processing waste and materials used.**

1. Turn plate through 90° before inserting the moving part.

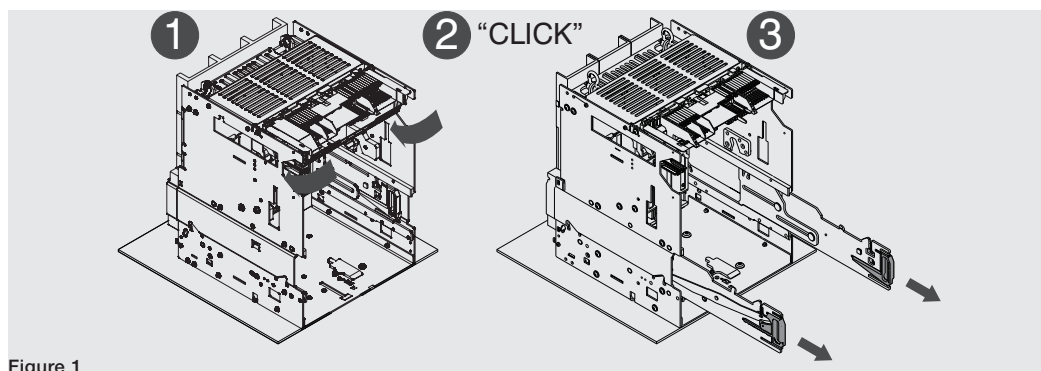

Figure 1

2. Position the lifting plates on the mobile part making sure that the tongue of the plates is latched properly. See Figure 37.

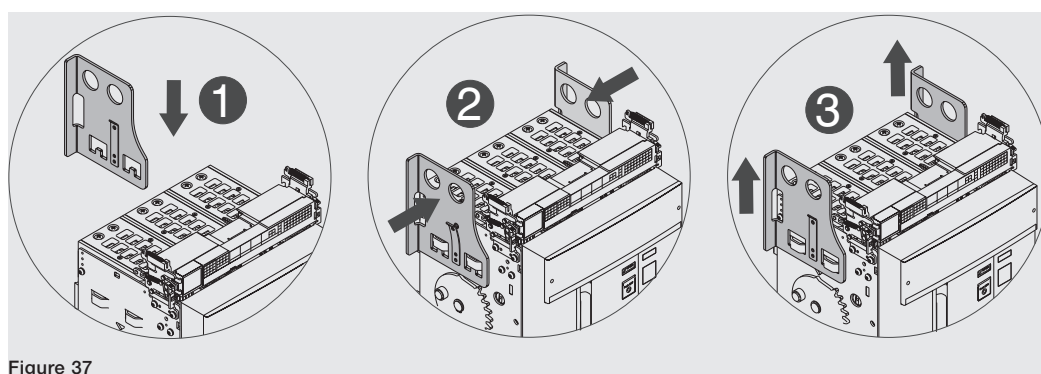

Figure 37

3. Extract the guides of the fixed part using the appropriate levers. See Figure 38.
4. Position the moving part on the guides of the fixed part. Latch by inserting the hollow part of the side in the latch of the guide of the fixed part See Figure 39.

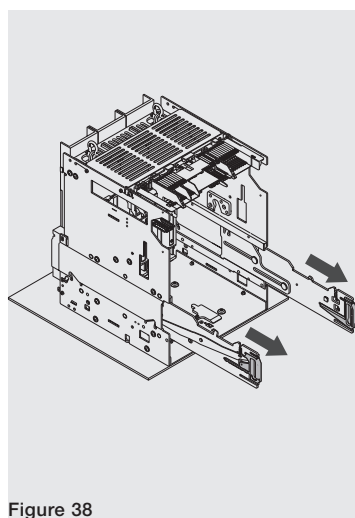

Figure 38

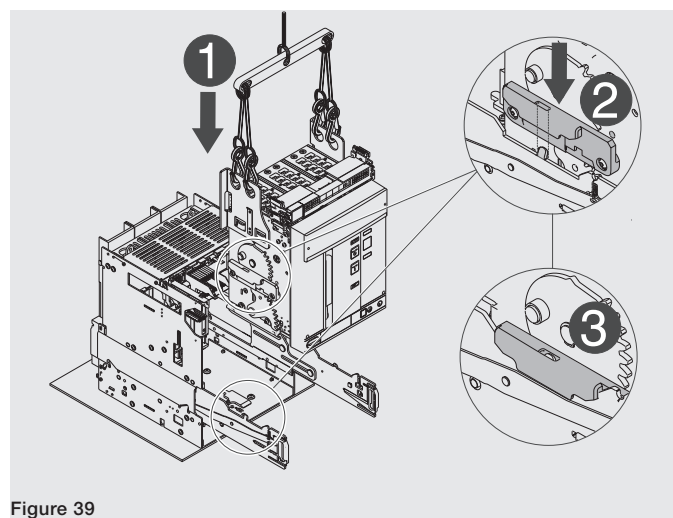

Figure 39

Continued on the next page

5. Unlatch the tongue and remove the lifting plates from the moving part. See Figure 40.

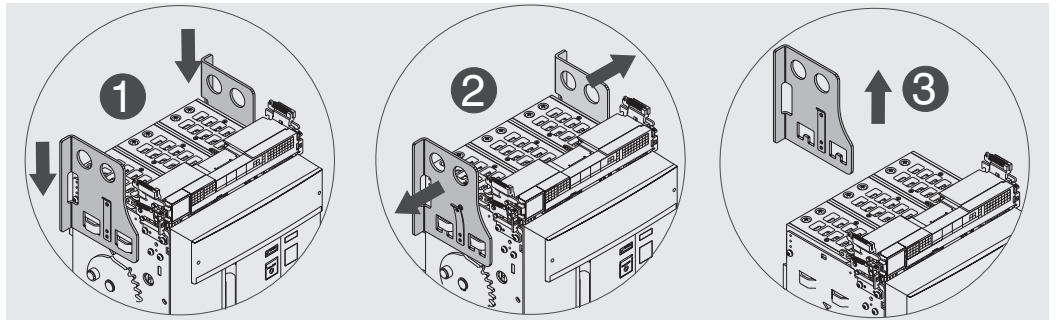

Figure 40

6. Make sure that the signalling device indicates the **DISCONNECT** position. See Figure 41.

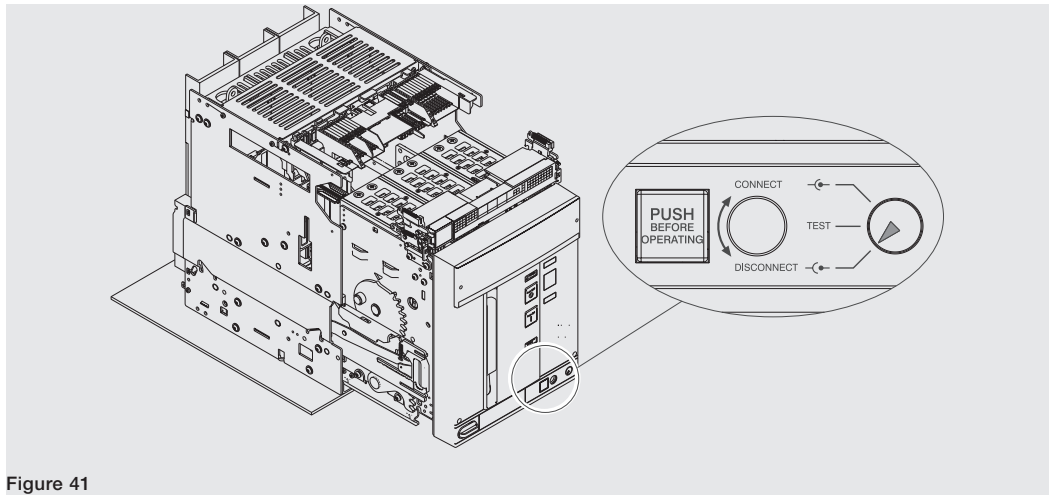

Figure 41

7. Grip the guide levers of the fixed part and push them until the moving part stops. See Figure 42.

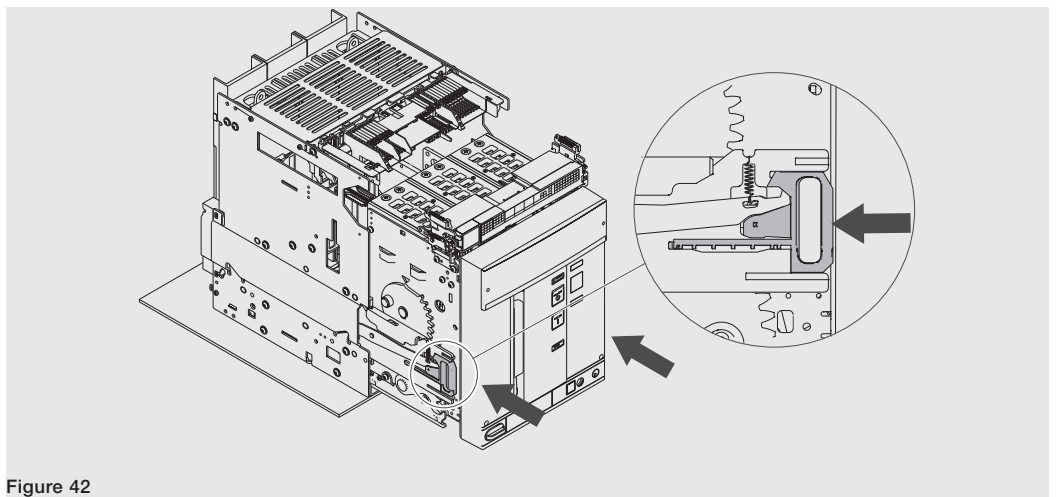

Figure 42

Continued on the next page

8. Extract the disconnection crank from its housing See Figure 43.
9. Press the lock pushbutton and insert the crank in the moving part. In this phase the moving part is still in **DISCONNECT** position. See Figure 44.

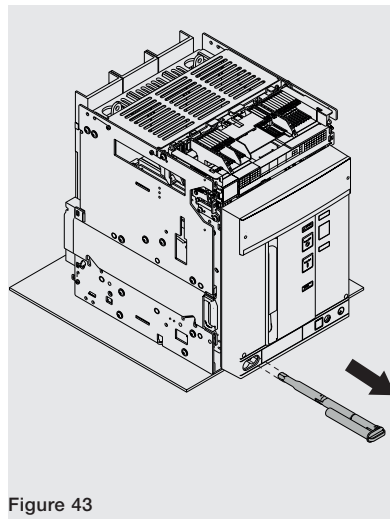

Figure 43

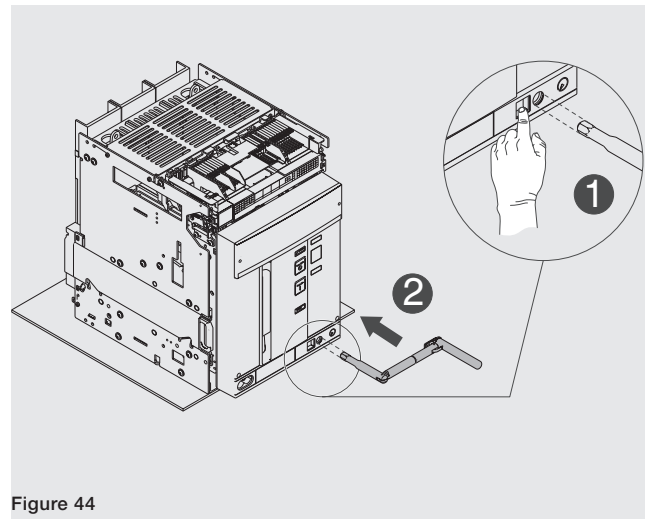

Figure 44

10. Turn the crank clockwise until the pushbutton comes out and the indicator shows that the circuit-breaker is in **TEST** position. See Figure 45.

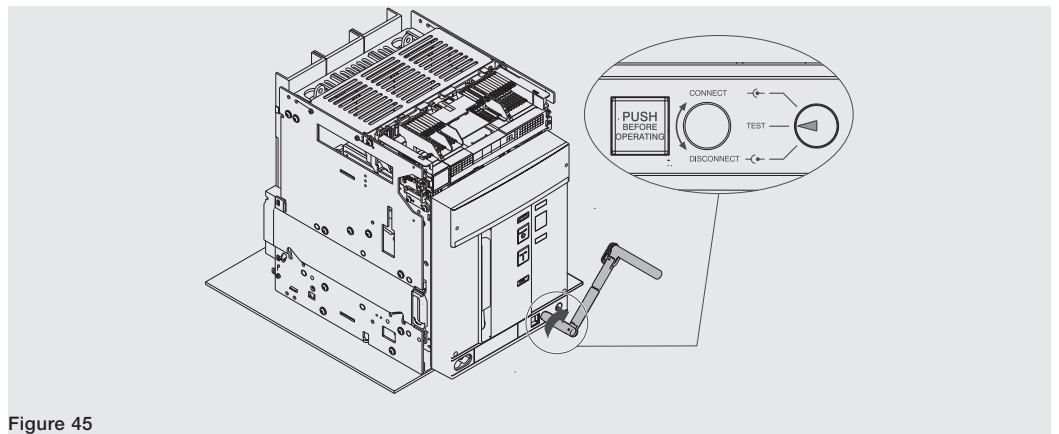

Figure 45

11. Press the lock button and rotate the crank clockwise until it comes out and the indicator shows that the circuit-breaker is in **CONNECT** position. See Figure 46.

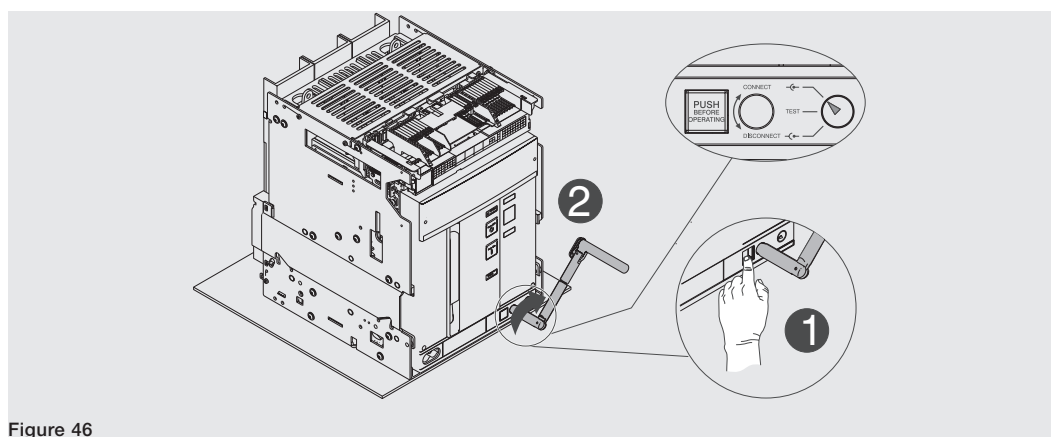

Figure 46

Continued on the next page

12. Extract the crank. See Figure 47.

13. Replace the crank in its housing See Figure 48.

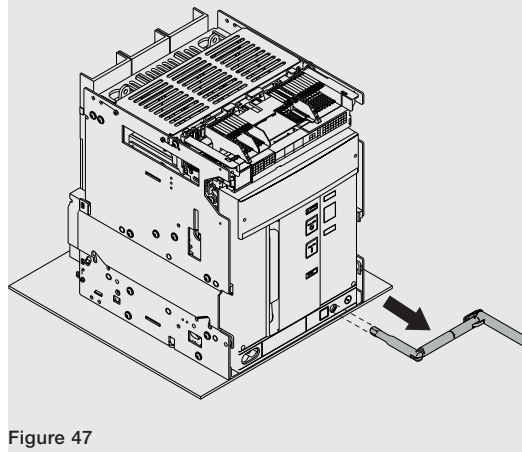

Figure 47

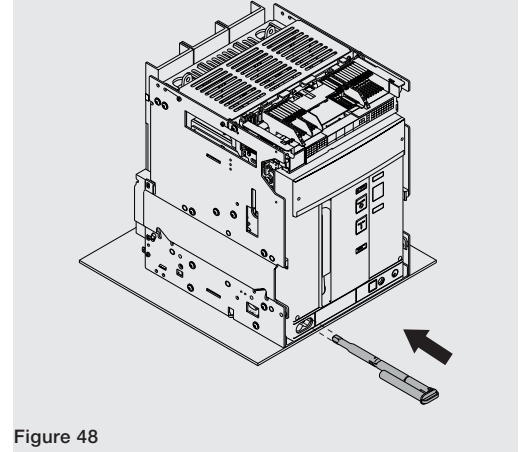

Figure 48



**WARNING!** The inserted circuit-breaker must be opened in order to be able to reach the test position. Discharge the springs before removing the circuit-breaker from the fixed part. On the UL version, the fail safe prevents the removal of the circuit-breaker from the fixed part with springs charged. For further details, consult the Mechanical safety accessories chapter in document [1SDH001330R1002](#).

To extract the moving part from the fixed part, perform the same steps indicated for insertion in reverse order.

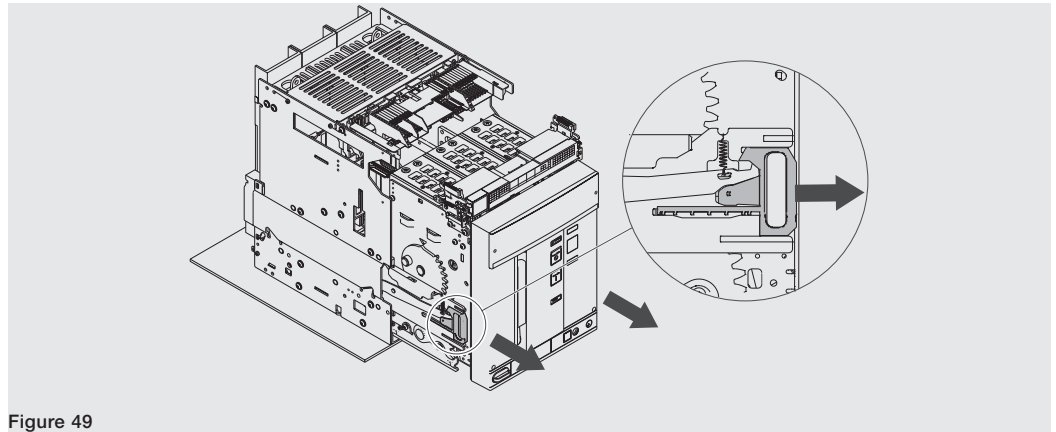

Figure 49

Continued on the next page

Always use both levers of the guides on the fixed part when racking out the circuit-breaker. See Figure 49.

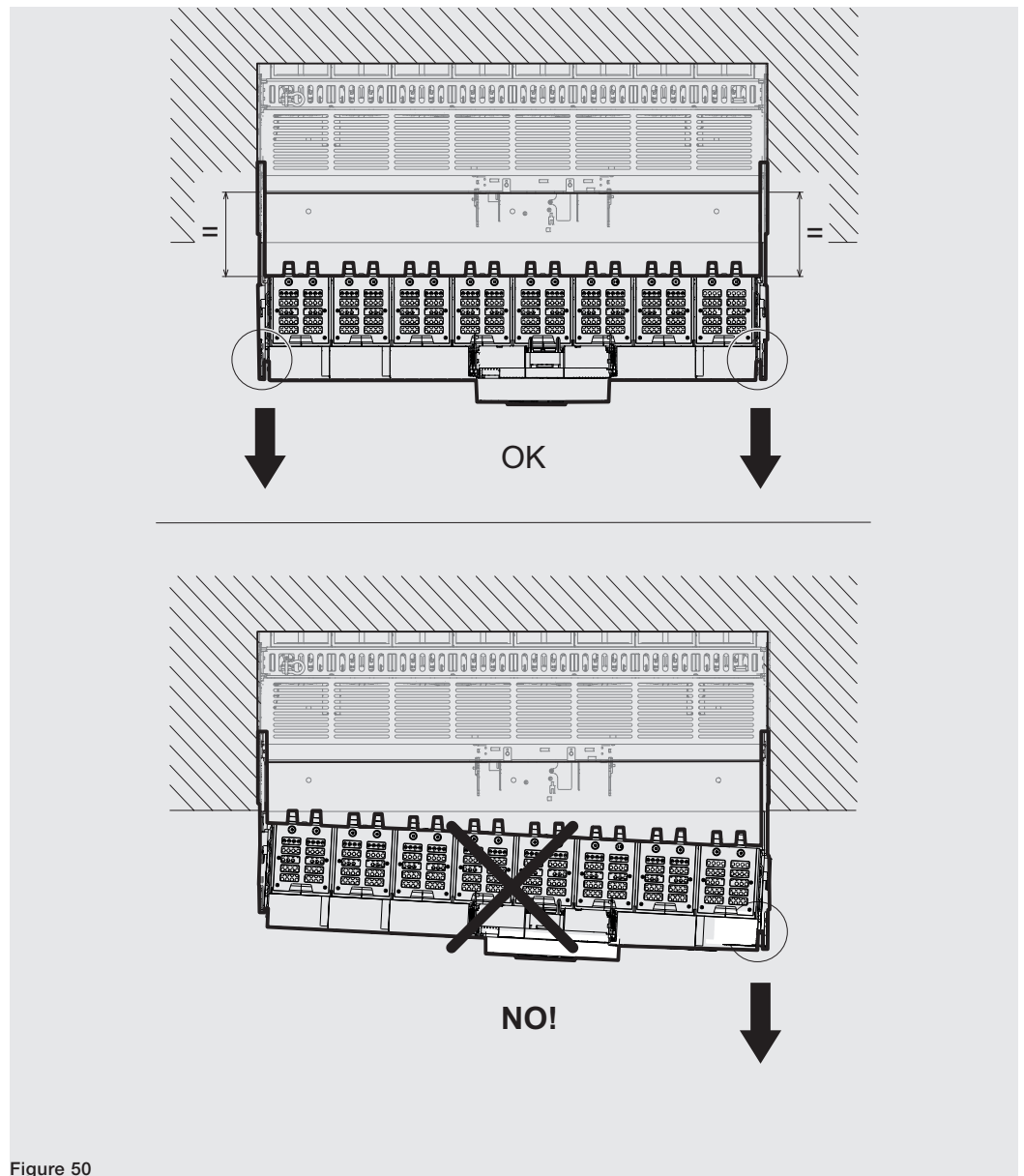

Figure 50

**⚠ WARNING!** When withdrawing the moving part, make sure that both guides on the fixed part travel to the same extent, thereby keeping the moving part parallel to the fixed part. See Figure 50.

### Mechanical position indicators

The following are the possible positions where you can find the mobile part of a withdrawable circuit-breaker during its use:

- circuit breaker in DISCONNECT position (see Figure 51)
- circuit-breaker in test position (see Figure 52)
- circuit-breaker in CONNECT position (see Figure 53)

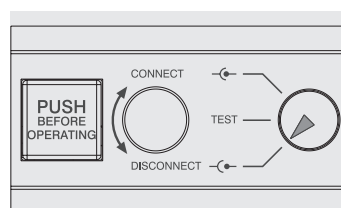

Figure 51

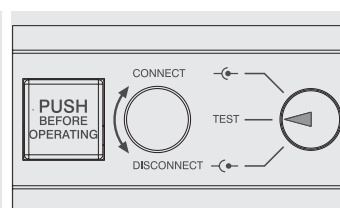

Figure 52

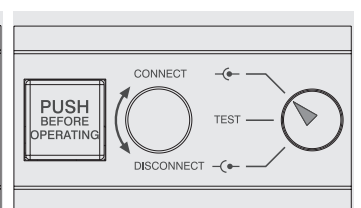

Figure 53



## 4 - Environmental conditions

Details related to this chapter are available in the manual [1SDH001330R1002](#) (Emax 2 engineering manual) available on the website ABB library.

## 5 - Installation

### Warnings and precautions before the installation

The following warnings and precautions must be respected before installing the circuit-breaker in the switchgear



#### WARNING!

- **Disconnect the power from the circuit-breaker (power circuit and auxiliary circuits)**
- **Make sure the circuit-breaker is disconnected from all sources of energy**
- **Switch the circuit-breaker to the open position with springs discharged**



**NOTE:** *The trained personnel in charge of handling and lifting must use appropriate safety equipment.*

### Mounting of the fixed circuit-breaker

Fix the circuit-breaker to a horizontal surface using 4 x M10 screws. See Figure 54.

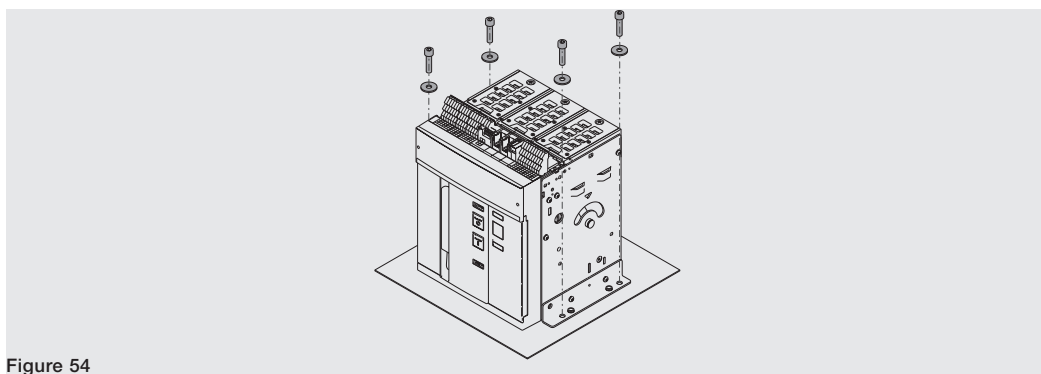

Figure 54



**WARNING! Emax E2.2-E4.2-E6.2 circuit breakers can only be installed in vertical position**

### Mounting anti-insertion locks

Before installing the fixed part, it is necessary to fit the lock that prevents the insertion of circuit-breakers with different electrical characteristics from the fixed part. See Figure 55.

Information on the assembly is available on the website <http://www.abb.com/abblibrary/DownloadCenter/>, in particular with the kit sheet [1SDH001000R0701](#).

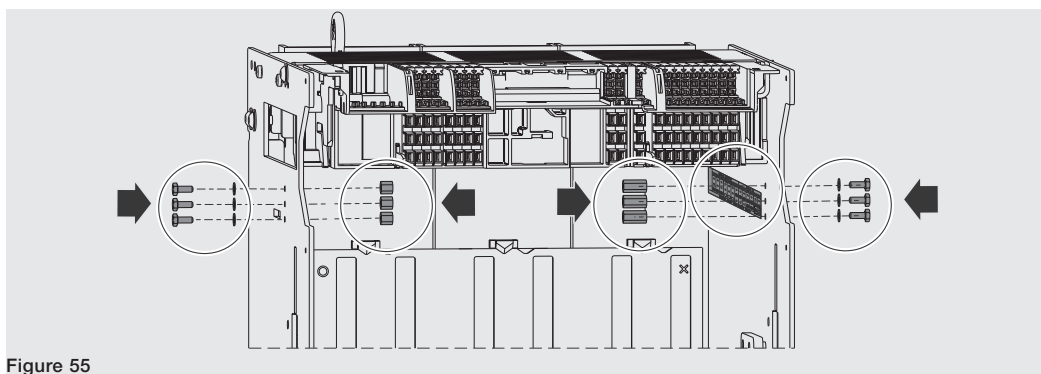

Figure 55

## Mounting the fixed part of the withdrawable circuit-breaker

Fasten the fixed part to a horizontal surface using four M8 x 25 screws for E2.2 and E4.2 fixed parts, and using six M8 x 25 screws for E6.2 fixed parts. The screws are supplied by ABB. See Figure 56. Tighten the screws with tightening torque = 21 Nm - 186 lb.in

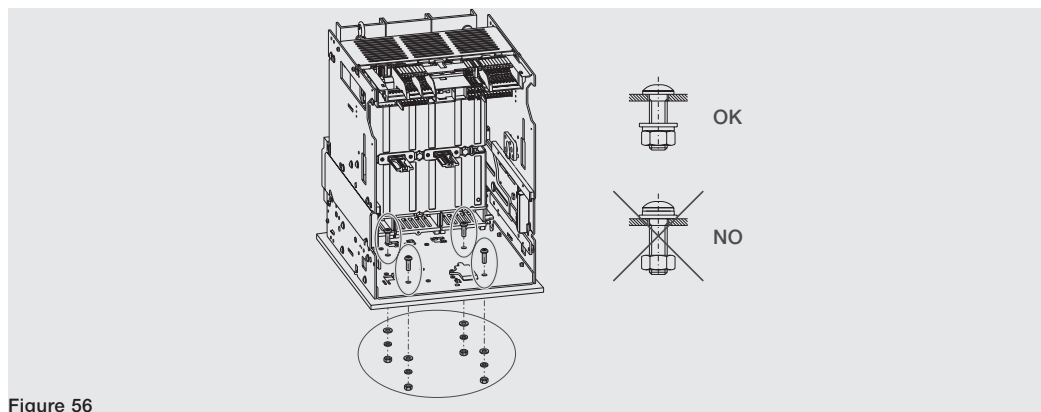

Figure 56



**WARNING! Emax E2.2-E4.2-E6.2 circuit breakers can only be installed in vertical position**

### Lateral fixing (only for circuit-breakers to "IEC 60068-2-6 Test Fc" standards)

Further details about lateral fixing of fixed parts are available at <http://www.abb.com/abblibrary/DownloadCenter/>, especially in the kit sheet [1SDH001000R0821](#).

## Types of terminal

SACE Emax 2 circuit-breakers can be equipped with different combinations of terminals for the upper and lower part. The following are the different types of terminal:

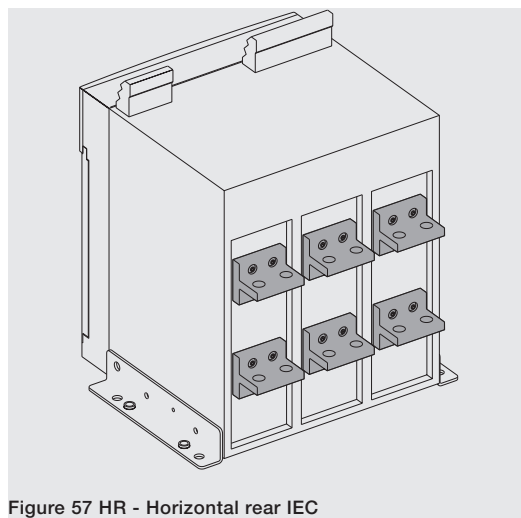

Figure 57 HR - Horizontal rear IEC

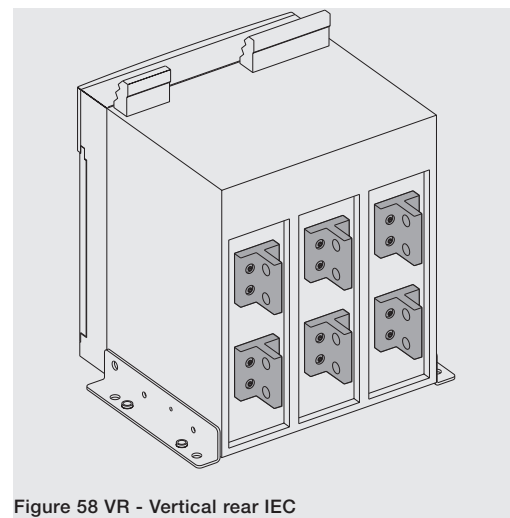

Figure 58 VR - Vertical rear IEC

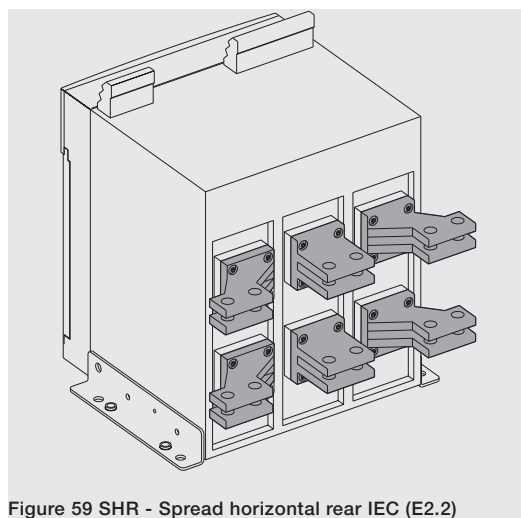

Figure 59 SHR - Spread horizontal rear IEC (E2.2)

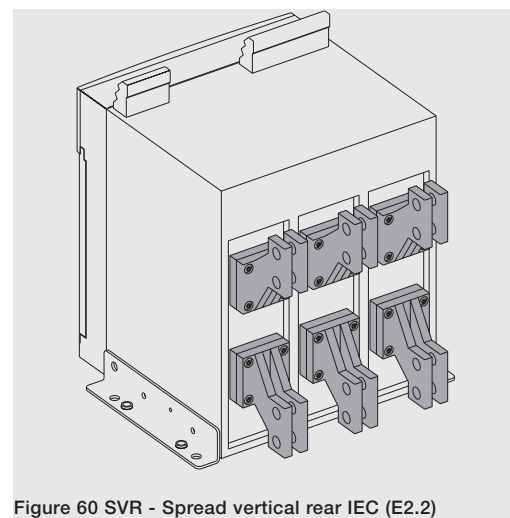

Figure 60 SVR - Spread vertical rear IEC (E2.2)

Continued on the next page

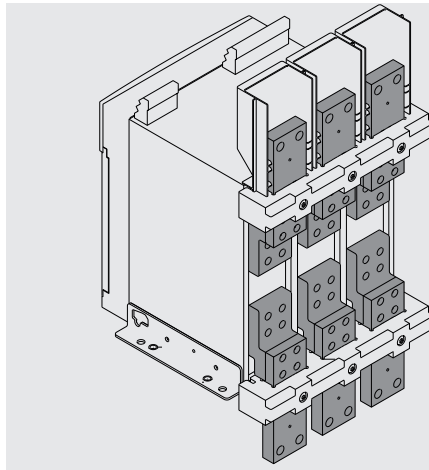

Figure 61 F - Frontal IEC-UL

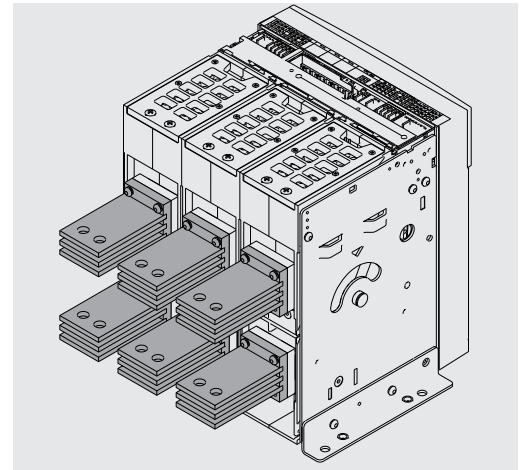

Figure 62 HR - Horizontal rear UL Listed

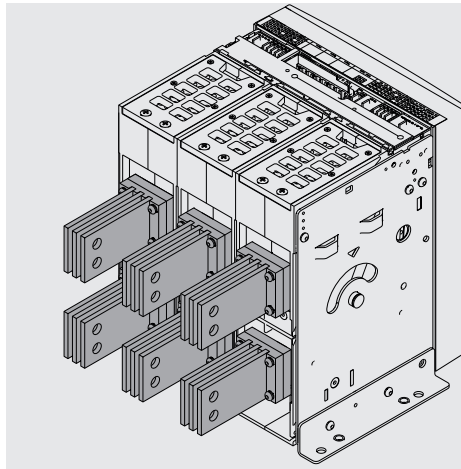

Figure 63 VR - Vertical rear UL Listed

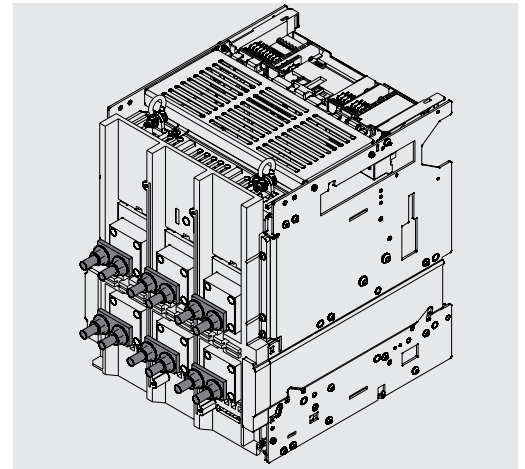

Figure 64 FL - Flat IEC

**Terminal compatibility**

The table of terminals available for each circuit-breaker is given below.

			F	HR/VR	SHR	SVR	FL
E2.2	IEC	<=690V	X	X	X	X	X <sup>(*)</sup>
		800V/900V	-	X	X	X	-
		1000/1150V	-	X	-	-	-
E4.2	UL <sup>(**)</sup>	<=600V	X	X	-	-	-
		<=690V	X	X	-	-	X <sup>(*)</sup>
		800V/900V	-	X	X	X	-
E6.2	IEC	1000/1150V	-	X	-	-	-
		<=690V	X	X	-	-	X <sup>(*)</sup>
		<=600V	X	X	-	-	-

## Change of position of the vertical/horizontal terminals

If the circuit-breaker is supplied equipped with terminals of the horizontal/vertical rear type, it is possible at any time to switch from horizontal to vertical and vice versa, except for E4.2 UL 3200A versions. (see Figure 65 IEC and Figure 66 IEC). Lock the screws with the following tightening torques:

- E2.2 - M6 screws - Tightening torque 8.6 Nm - 70.8 lb.in
- E4.2 and E6.2 - M8 screws - Tightening torque 20 Nm - 177 lb.in

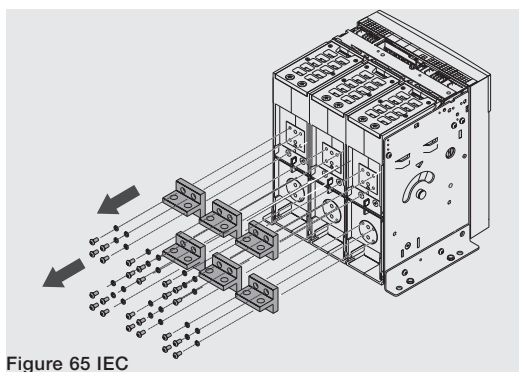

Figure 65 IEC

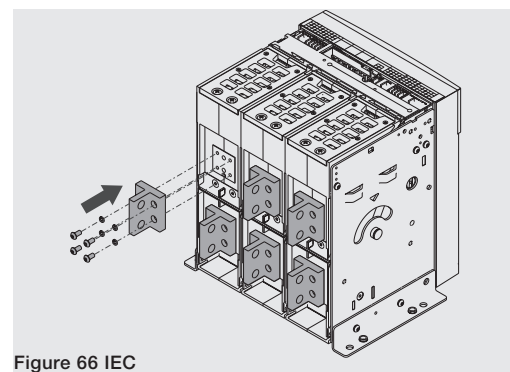

Figure 66 IEC

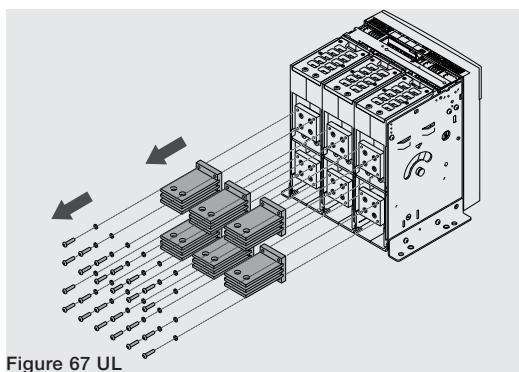

Figure 67 UL

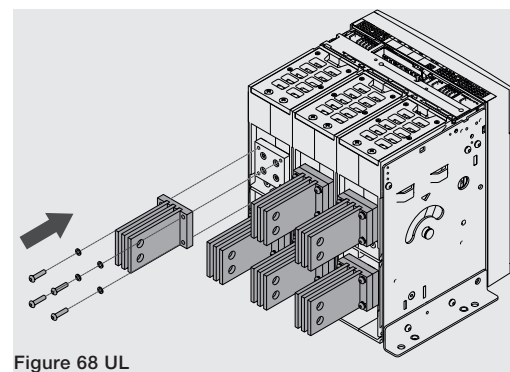

Figure 68 UL

**Clearances** Information on clearances is available on the website:

<http://www.abb.com/abblibrary/DownloadCenter/>.

The following drawing is also available in .dxf format: [1SDH001301R0001](#) - Cubicle E1.2-E2.2-E4.2-E6.2

## Phase separators

Phase separators are available on request. Alternatively, it is possible to position the insulation barriers to segregate live parts. In addition, the phase separators are mandatory:

- If, between two phases, the minimum distance between the screws that fix the circuit-breaker terminals to the connection bars is less than 14 mm - 0.55".
- For circuit breakers version >690V.

Information on the assembly is available on the website <http://www.abb.com/abblibrary/DownloadCenter/>, in particular with the kit sheet [1SDH001000R0810](#).

## Connection to the power circuit

The connection of a circuit-breaker to the power circuit is performed using the connection busbars of the electric switchgear fixed to the terminals of the circuit-breaker. The sizing of the busbars is specified by the designer of the electrical switchgear.

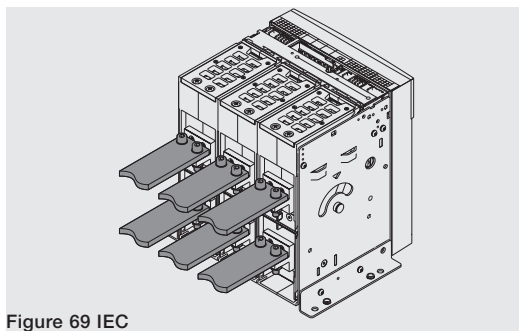

Figure 69 IEC

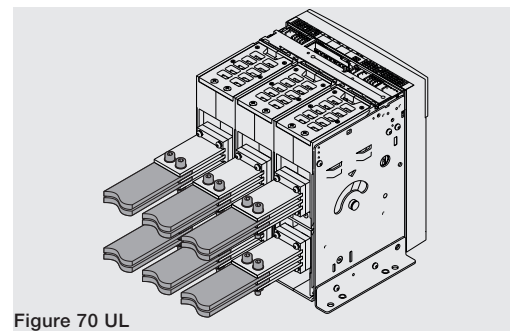

Figure 70 UL

Continued on the next page



**IMPORTANT: it is possible to obtain different capacities for the connections by altering the thickness and number of busbars in parallel.**

The following tables provide some examples of the quantity and the sizes of the connections that can be used for each type of circuit-breaker:

circuit-breaker IEC 60947	I <sub>u</sub> (A)	Horizontal terminals		Vertical terminals	
		Q.ty	Dimension of busbars (in)	Q.ty	Dimension of busbars (in)
E2.2	800	1	50x10	1	50x10
	1000	2	50x5	2	50x5
	1250	2	50x10	2	50x10
	1600	2	2x60x10	1	100x10
	2000	3	60x10	2	80x10
		3	60x10 <sup>(1)</sup>	2	80x10 <sup>(1)</sup>
2500	3	60x10	4	100x5	
	3	60x10 <sup>(1)</sup>	4	100x5 <sup>(1)</sup>	
E4.2	2000	2	80x10	2	80x10
	2500	2	100x10	2	100x10
	3200	3	100x10	3	100x10
	4000	4	100x10	4	100x10
E6.2	4000	4	100x10	4	100x10
	5000	5	100x10	5	100x10
	6300	6	100x10	6	100x10

<sup>(1)</sup> values for spread terminals

circuit-breaker UL 1066	I <sub>u</sub> (A)	Horizontal terminals		Vertical terminals	
		Q.ty	Dimension of busbars (in)	Q.ty	Dimension of busbars (in)
E2.2-A	1600	3	1/4 x 2,5	2	1/4 x 3
		4	1/4 x 2	3	1/4 x 2
	2000	4	1/4 x 2,5	4	1/4 x 2
E4.2-A	2000	4	1/4 x 2,5	4	1/4 x 2
	2500	4	1/4 x 4	3	1/4 x 4
	3200	-	-	4	1/4 x 4
-		-	5	1/4 x 3	
E6.2-A	4000	6	1/4 x 4	4	1/4 x 5
	5000	10	1/4 x 4	6	1/4 x 5



**IMPORTANT: before proceeding with the connection between terminals and connection busbars:**

- make sure that the contact surfaces of the busbars are free of burrs, dents, traces of rusting, dust or traces of grease.
- make sure, if aluminium busbars are used, than these are tin plated in the contact areas.
- make sure that the busbars do not exert forces in any direction on the terminal.
- for tightening use M12 screws or threaded rods with resistance class 8.8 equipped with spring washers and lock them with a torque of 70 Nm - 619.5 lb in.



**NOTE:** the information on the performances of the circuit-breakers in switchboards is available on the website:

<http://new.abb.com/low-voltage/products/circuit-breakers/emax2>.

**Dimensions** Information on the overall dimensions is available on the website:

<http://www.abb.com/abblibrary/DownloadCenter/>.

The following drawings are also available in .dxf format:

- [1SDH001000R0100](#) - E2.2 III-IV Fixed HR VR IEC
- [1SDH001000R0101](#) - E2.2 III-IV Fixed F IEC-UL
- [1SDH001000R0102](#) - E2.2 III-IV Withdrawable HR-VR IEC
- [1SDH001000R0103](#) - E2.2 III-IV Withdrawable F IEC
- [1SDH001000R0104](#) - E2.2 III-IV Fixed SHR IEC
- [1SDH001000R0105](#) - E2.2 III-IV Withdrawable SHR IEC
- [1SDH001000R0106](#) - E2.2 III-IV Fixed SVR IEC
- [1SDH001000R0107](#) - E2.2 III-IV Withdrawable SVR IEC
- [1SDH001000R0110](#) - E2.2 2000 III-IV Withdrawable FL IEC
- [1SDH001000R0111](#) - E2.2 2500 III-IV Withdrawable FL IEC
- [1SDH001001R0100](#) - E4.2 III-IV Fixed HR VR IEC
- [1SDH001001R0101](#) - E4.2 III-IV Fixed F IEC
- [1SDH001001R0102](#) - E4.2 III-IV Withdrawable HR-VR IEC
- [1SDH001001R0103](#) - E4.2 III-IV Withdrawable F IEC
- [1SDH001001R0104](#) - E4.2/E9, E4.2/E III-IV Fixed SHR IEC
- [1SDH001001R0105](#) - E4.2/E9, E4.2/E III-IV Withdrawable SHR IEC
- [1SDH001001R0106](#) - E4.2/E9, E4.2/E III-IV Fixed SVR IEC
- [1SDH001001R0107](#) - E4.2/E9, E4.2/E III-IV Withdrawable SVR IEC
- [1SDH001001R0110](#) - E4.2 3200 III-IV Withdrawable FL IEC
- [1SDH001001R0111](#) - E4.2 4000 III-IV Withdrawable FL IEC
- [1SDH001060R0100](#) - E6.2 III-IV Fixed HR IEC
- [1SDH001060R0101](#) - E6.2 III-IV Fixed VR IEC
- [1SDH001060R0102](#) - E6.2 IV FS Fixed HR-VR IEC
- [1SDH001060R0104](#) - E6.2 III-IV Fixed F IEC
- [1SDH001060R0105](#) - E6.2 III-IV Withdrawable HR IEC
- [1SDH001060R0106](#) - E6.2 III-IV Withdrawable VR IEC
- [1SDH001060R0107](#) - E6.2 IV FS Withdrawable HR-VR IEC
- [1SDH001060R0108](#) - E6.2 III-IV Withdrawable F IEC
- [1SDH001060R0110](#) - E6.2 6300 III-IV Withdrawable FL IEC
- [1SDH001000R0120](#) - E2.2-E4.2-E6.2 Fixed Withdrawable Flange IEC-UL
- [1SDH001000R0121](#) - E2.2-E4.2-E6.2 Fixed internal mounting IEC-UL
- [1SDH001000R0300](#) - E2.2 III-IV Fixed HR-VR UL
- [1SDH001000R0302](#) - E2.2 III-IV Withdrawable HR-VR UL
- [1SDH001000R0303](#) - E2.2 III-IV Withdrawable F UL
- [1SDH001001R0300](#) - E4.2 III-IV Fixed HR-VR UL
- [1SDH001001R0302](#) - E4.2 III-IV Withdrawable HR-VR UL
- [1SDH001001R0303](#) - E4.2 III-IV Withdrawable F UL
- [1SDH001001R0304](#) - E4.2 III-IV Fixed HR-VR UL
- [1SDH001001R0305](#) - E4.2 III-IV Withdrawable HR-VR UL
- [1SDH001001R0306](#) - E4.2 3600 III-IV Fixed UL
- [1SDH001060R0300](#) - E6.2 III-IV Fixed HR UL
- [1SDH001060R0301](#) - E6.2 III-IV Fixed VR UL
- [1SDH001060R0302](#) - E6.2 IV FS Fixed HR-VR UL
- [1SDH001060R0305](#) - E6.2 III-IV Withdrawable HR UL
- [1SDH001060R0306](#) - E6.2 III-IV Withdrawable VR UL
- [1SDH001060R0307](#) - E6.2 IV FS Withdrawable HR-VR UL
- [1SDH001060R0308](#) - E6.2 III-IV-IV FS Withdrawable F UL
- [1SDH001060R0309](#) - E6.2 III-IV Fixed VR UL
- [1SDH001060R0310](#) - E6.2 IV FS Fixed VR UL
- [1SDH001060R0311](#) - E6.2 III-IV Withdrawable VR UL
- [1SDH001060R0312](#) - E6.2 IV FS Withdrawable VR UL
- [1SDH001060R0313](#) - E6.2 6000 III Withdrawable VR UL

**Positioning anchor plates**

The diagram below indicates the distance for positioning the first anchor plate according to the circuit-breaker type and the peak current:

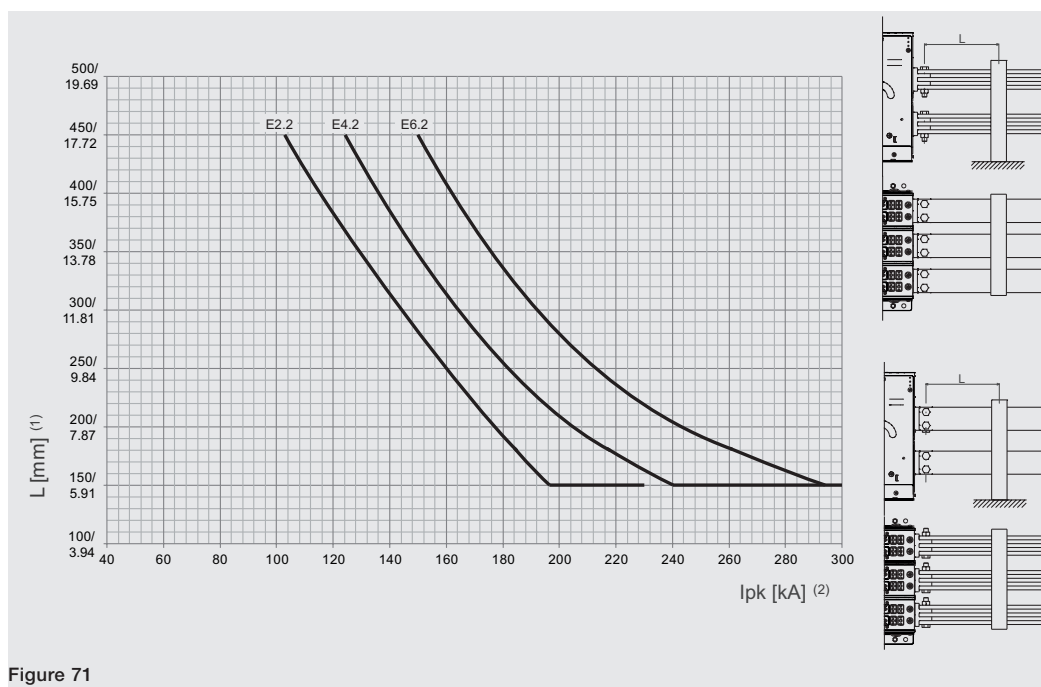

Figure 71

(1): distance of the first anchor plate from the circuit-breaker terminals

(2): peak current

**Positioning anchor plates E4.2-A 3600A**

The anchor plates for E4.2-A 3600A circuit-breakers must be positioned as indicated in the figure.

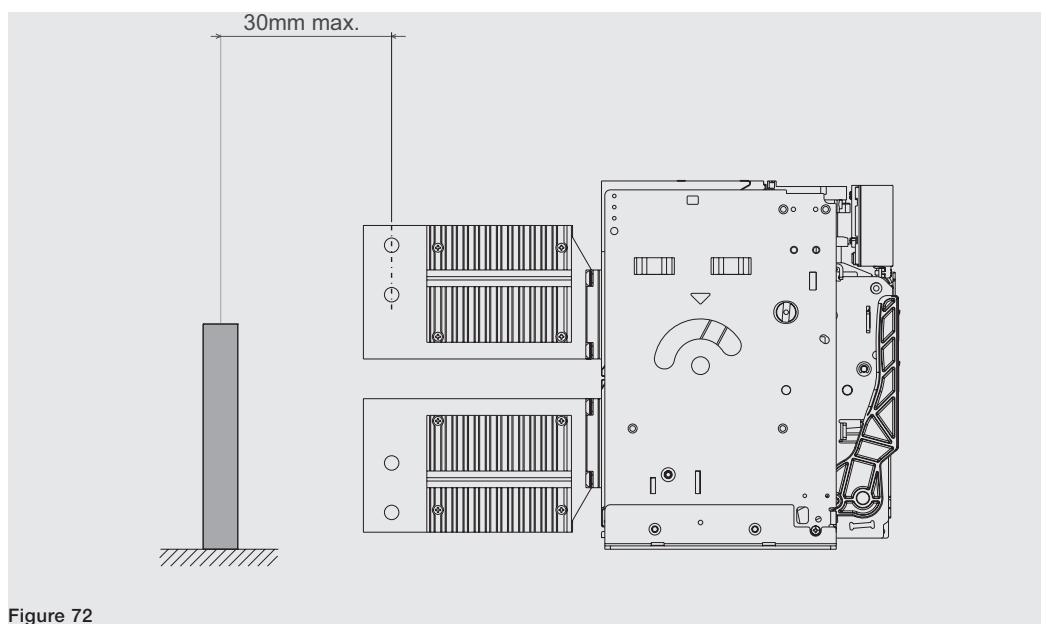

Figure 72

**>690V version circuit-breakers**

Insulating protections must be assembled for >690V circuit-breakers as indicated in the figure.

Circuit-breaker	Voltage	Version	Fixed protection	Withdrawable protection
E2.2/E9	800V/900V	F	X	-
		W	-	-
E2.2/E	1000V/1150V	F	X	-
		W	-	X
E4.2/E9	800V/900V	F	X	-
		W	-	-
E4.2/E	1000V/1150V	F	X	-
		W	-	X
E6.2/E9	800V/900V	F	X	-
		W	-	-
E6.2/E	1000V/1150V	F	X	-
		W	-	X

Information on the assembly is available on the website <http://www.abb.com/abblibrary/DownloadCenter/>, in particular in the kit sheet [1SDH001000R0746](#) for fixed circuit-breakers and in the kit sheet [1SDH001000R0747](#) for withdrawable circuit breakers.

**Grounding** The circuit-breakers in fixed version and the fixed part of withdrawable circuit-breakers are equipped with a screw for the ground connection.

The connection must be implemented by means of a conductor of suitable cross-section according to the IEC 61439-1 Standard.

Clean and degrease the area around the screw before making the connection.

After assembly of the conductor, tighten the screw with a torque of 2 Nm - 17.7 lb in.

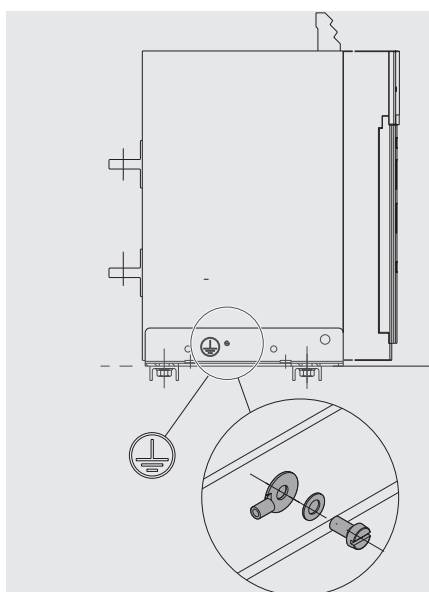

Figure 73

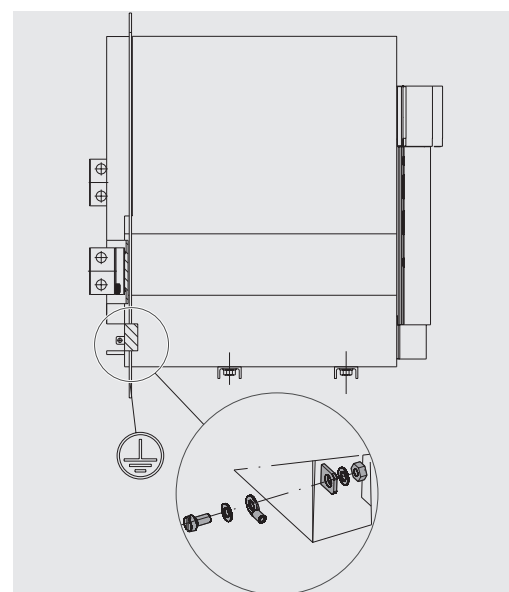

Figure 74



# Ekip Dip

## 1 - General characteristics

**Families** SACE Emax 2 can be configured with two families of Trip units:

- Ekip Dip with interface via dip-switches
- Ekip Touch with touchscreen display

Both families provide protection and measuring functions related to signals from the installation and are available in different models and versions.

Details of Ekip Dip are given in this document; for a description of Ekip Touch, consult document [1SDH001316R1002](#).

**Versions and main functions** Ekip Dip is available in three versions: Ekip Dip LI, Ekip Dip LSI, Ekip Dip LSIG.

All versions provide the following functionalities:

- *Measurement* of installation currents
- *Protection*: depending on the measurements made and the parameters configured by the user, the Trip unit checks for the presence of alarms and commands circuit-breaker opening if necessary
- *Signalling*: management of contacts and communication networks to optimize plant efficiency, communication among different CB and other functions

The Ekip Dip functions are provided both by means of transducers and actuators inside the circuit-breaker, and by means of a vast range of external accessories

### Presentation

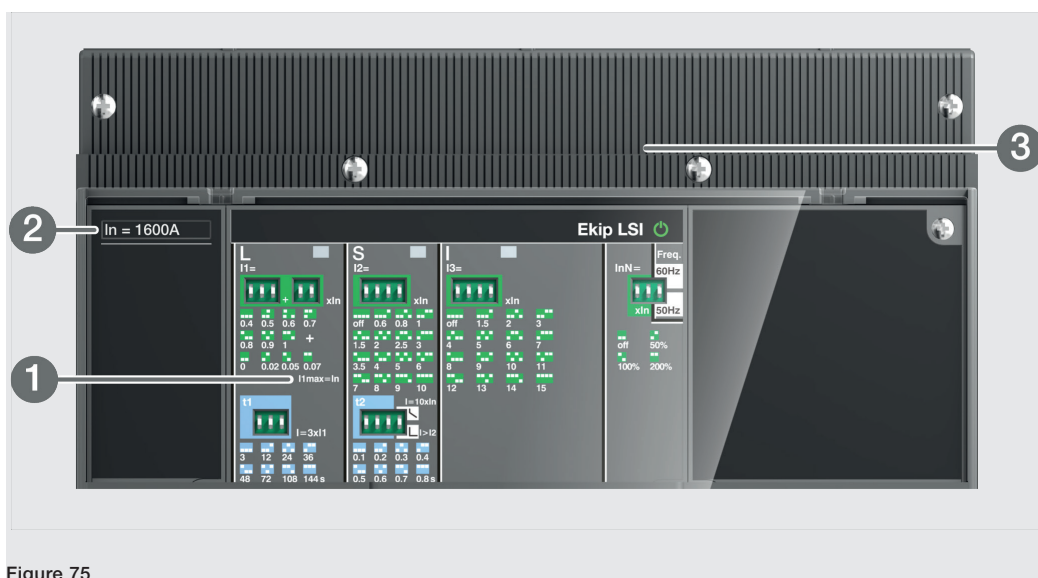

Figure 75

Ekip Dip has a dip-switch (1) interface for configuring and verifying the protections and main parameters (page 33).

The nominal size of the Rating plug (2) can be checked on the front (page 49).

All the external connections, including the supply and communication modules, the external sensors and mechanical accessories, are available in the upper terminal box (3) (page 48 for an overview of the electronic accessories).

## 2 - Operating features

**Introduction** Ekip Dip has been developed and certified to function in specific environmental, electrical and mechanical conditions; full details are available in the *Technical catalog*.

The following sections describe the electrical and power supply characteristics that enable Ekip Dip and the relative electronic accessories to operate correctly.

**Electrical characteristics** The Ekip Dip measurement and protection functions described in this document are guaranteed with current values within the following nominal ranges:

Parameter	Rated operating range
Primary current	0,004 ÷ 16 I <sub>n</sub> <sup>(1)</sup>
Rated frequency	45 ... 55 Hz (with fn= 50 Hz) / 54 ... 66 Hz (with fn= 60 Hz)
Peak factor	Complying with standard IEC 60947-2

<sup>(1)</sup> range with reference to each phase; I<sub>n</sub> refers to the rated size defined by the Rating plug installed on the Trip unit, available in models from 100 A to 6300 A

**Self-supply** The internal current sensors are able to supply the Trip unit directly

Parameter	Operating limits
Minimum three-phase turn-on current	> 30 A (E2.2 with Rating Plug < 400 A)
	> 80 A (E2.2 with Rating Plug ≥ 400 A and E4.2)
	> 160 A (E6.2)

**Auxiliary power supply** Ekip Dip can be connected to an external auxiliary supply source, which is useful when certain functions such as communication via Local Bus, recording manual operations, certain measurements and the datalogger must be activated.

The auxiliary supply can be provided by modules from the Ekip Supply range or via a direct connection to the terminal box; the direct connection must be made when the following operating conditions can be guaranteed:

Parameter	Operating limits
Voltage	24 VDC galvanically isolated
Tolerance	± 10%
Maximum ripple	± 5%
Maximum inrush current @ 24 V	10 A per 5 ms
Maximum rated power @ 24 V	4 W
Connection cable	Insulated with grounding cable (same characteristics as Belden 3105A/B or higher)



**IMPORTANT: if connection is direct, the power supply must be galvanically insulated and provide the insulation characteristics established by standard IEC 60950 (UL 1950) or equivalent.**

## 3 - Operator interface

**Introduction** The operator interface of the Ekip Dip protection trip unit allows you to:

- Set the parameters relating to the available protections.
- View the status of the trip unit and alarms.
- Connect to the frontal connector to communicate and perform the opening test.

**Components of the interface** The Ekip Dip operator interface appears as follows:

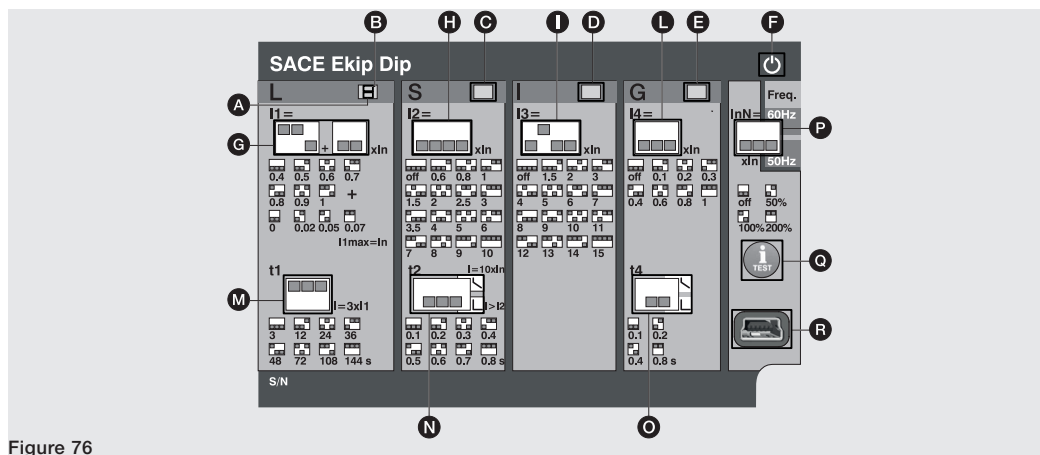

Figure 76

The following table provides a description of the components of the interface:

Position	Type	Description
A	<b>LED</b>	L Protection LED (alarm and trip)
B		L Protection LED (pre-alarm)
C		S Protection LED (alarm and trip)
D		I Protection LED (trip)
E		G Protection LED (alarm and trip)
F		Power-on LED (trip unit powered and on)
G	<b>Protections: thresholds</b>	L Protection dip-switch (threshold I1)
H		S Protection dip-switch (threshold I2)
I		I Protection dip-switch (threshold I3)
L		G Protection dip-switch (threshold I4)
M	<b>Protections: times</b>	L Protection dip-switch (time t1)
N		S Protection dip-switch (time t2 and type of curve)
O		G Protection dip-switch (time t4 and type of curve)
P	<b>Settings</b>	Neutral and frequency dip-switch
Q	<b>Test</b>	Test pushbutton
R		Test connector



**IMPORTANT:** the figure above refers to an Ekip Dip, LSIG version. In the case of Ekip Dip LI or LSI versions, LEDs and dip-switches related only to the protections present are available.

**LEDs** The LEDs are useful on Ekip Dip in order to distinguish and identify various types of information on the protection trip unit, the circuit-breaker and state of the line currents.

#### **Operational conditions**

The operation of the LED is determined by the power supply conditions of the trip unit:

- With the trip unit energized (by current sensors or by auxiliary power supply or by Ekip TT or by Ekip T&P or by Ekip Bluetooth) the LEDs are operational for all the signals.
- With the trip unit de-energized, the LEDs are limited to the signalling of the last switch-off or trip event (combined with the check via iTest, described below).



**NOTE:** *with the trip unit off, the operation of the LEDs is guaranteed if the internal battery of the trip unit is working properly.*

#### **About**

The LEDs combined with the protections provide various information, through different combinations of lighting and blinking.



**NOTE:** *all the combinations related to protection LED signals are described in chapter **Self-diagnosis and signalling** , on page 45.*

The power-on LED provides information about the power status of the protection trip unit:

- LED on (default configuration) fixed or blinking, signals trip unit energized.
- LED off signals trip unit de-energized.



**NOTE:** *with Ekip T&P and Ekip Bluetooth modules and Ekip Connect software, it is possible to configure how the power LED functions (LED fixed or blinking).*

---

**Protections: thresholds** The thresholds of all the protections can be modified with various dip-switches, as specified on the serigraph of the interface.

The values of the protections make reference to the current  $I_n$ , a nominal value defined by the Rating Plug.



#### **IMPORTANT:**

- **Modification of the thresholds must be performed in the absence of protection alarms.**
- **Modifications carried out in alarm conditions are accepted by the trip unit when resting condition is restored (absence of protection alarms).**

---

**Protections: times** The times and the curves of the protections can be modified with various dip-switches, as specified on the serigraph of the interface.



#### **IMPORTANT:**

- **Modification of the times must be performed in the absence of protection alarms.**
- **Modifications carried out in alarm conditions are accepted by the trip unit when resting condition is restored (absence of protection alarms).**

---

**Settings** Two further settings are available:

- **Neutral** allows activation and adjustment of the protections on the neutral pole.
  - **Frequency** allows the selection of the installation frequency.
-

- 
- iTest pushbutton** The iTest pushbutton is useful for three operations:
- Perform tests (circuit-breaker opening test and LED test). Consult chapter 6 - Test on page 44.
  - Reset the signal of the tripped protection. This operation can be performed when the circuit-breaker is both open and closed and with currents present, by pressing the push-button for about 1 second (the signal disappears when the push-button is released).
  - With the trip unit off, check the information relating to the switch-off or tripping event.



**NOTE:** *with the trip unit off, pressing of the iTest button switches on (for approximately 4 seconds):*

- the power-on LED, if the trip unit is off due to an energy drop (primary current less than the minimum level of operation, removal of auxiliary power supply with circuit-breaker open, etc...).
- the protection tripped LED if the trip unit is off due to a protection trip.

- 
- Test connector** The test connector allows the connection of Ekip TT, Ekip T&P and Ekip Bluetooth modules, in order to perform the following operations:
- Temporary energizing of the trip unit to check the status, and perform the trip test (option possible with all the front interface modules).
  - Analysis, supervision and setting of additional parameters through external communication test units (Ekip T&P, Ekip Bluetooth).
-

## 4 - Protections

**Operating principle** The protection functions are available with all Ekip Dip versions.

1. If the signal measured exceeds the set **threshold**, the specific protection activates (prealarm and/or **alarm**).
2. The **alarm** appears on the display and, after a period of time (timing  $t_1$ ), depending on the protection parameters set, can convert into a **trip command (TRIP)** transmitted to the internal Trip coil of the CB.



**NOTE:**

- if the signal measured drops below the set threshold before the trip time has elapsed, Ekip Dip quits the alarm and/or timing state and returns to the normal operating condition
- all protections have a default configuration: check the parameters and change to suit the installation requirements before putting into service
- to allow circuit-breaker tripping to be controlled by a specific protection, the protection itself must be enabled

**L Protection** L protection protects against overloads



**NOTE:** the protection is available and active for all the versions of the trip unit.

When the activation threshold is exceeded, the protection trips in a time that decreases as the current read increases.

**Parameters**

All the parameters that can be modified by the user affect the response curve, and related tripping times.

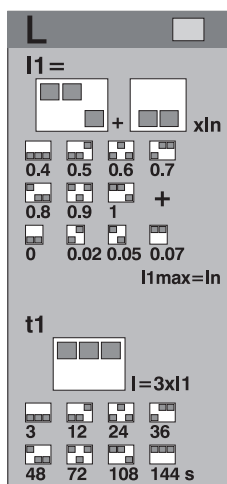
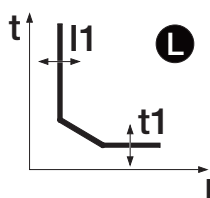

Parameter	Description
<b>Threshold I1</b>	<p>The value I1 contributes in calculating the tripping time, and also defines the current value that, if exceeded, activates the protection (with reference to the curve, it is the part parallel to the y-axis).</p> <p><b>IMPORTANT:</b></p> <ul style="list-style-type: none"> <li>• The protection is activated and starts timing for currents between 1.05 and 1.2 of the threshold I1 set <sup>(1)</sup>.</li> <li>• The delay is interrupted if the current drops below the activation threshold.</li> </ul>
<b>Time t1</b>	<p>The value t1 contributes in calculating the tripping time (with reference to the curve, T1 affects the entire curve by shifting it as a whole along the y-axis).</p> <p><b>IMPORTANT:</b></p> <p>The protection limits the tripping time to 1 second in two cases:</p> <ul style="list-style-type: none"> <li>• if, according to the calculation, the time is less than 1 second.</li> <li>• If the fault current is greater than 12 In.</li> </ul>

<sup>(1)</sup> Example (with I1 set to 400 A): the protection is activated for currents between 420 A and 480 A.

With the modules Ekip T&P or Ekip Bluetooth and with the Ekip Connect software, it is possible to activate the function **Thermal Memory**, and adjust the threshold of **Pre-alarm**.

**S Protection** S protection protects against selective short circuit.

**i** **NOTE:** the protection is available for LSI and LSIG versions of the trip unit.

When the activation threshold is exceeded, the protection trips within a fixed or dynamic time (the time decreases as the current reading increases).

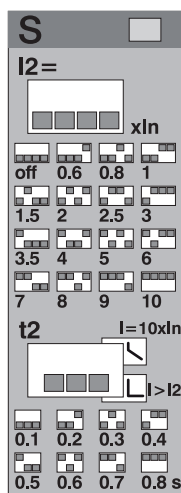
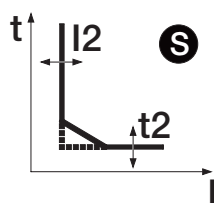

### Parameters

All the parameters that can be modified by the user affect the response curve, and related tripping times.

Parameter	Description
<b>Enable</b>	By setting the threshold dip-switches to the Off position, the protection is disabled.
<b>Type of curve</b>	It determines the dynamic of the curve and the tripping time, fixed or dynamic according to the selection: <b>i</b> <b>NOTE:</b> calculation of the tripping time of the inverse time curve is based on a mathematical expression. The details are provided in the table on page 42.
<b>Threshold I2</b>	It defines the current value that activates the protection when exceeded (with reference to the curve, it is the part parallel to the y-axis). <b>!</b> <b>IMPORTANT:</b> <ul style="list-style-type: none"> <li>• The I2 threshold set must be higher than the I1 threshold. An incorrect configuration returns an alarm signal.</li> <li>• The delay is interrupted if the current drops below the activation threshold.</li> </ul>
<b>Time t2</b>	The selected function determines the contribution of t2: <ul style="list-style-type: none"> <li>• Fixed time: t2 is the delay time between exceeding the I2 threshold and sending the opening command.</li> <li>• Dynamic time: t2 contributes in calculating the tripping time (with reference to the curve, t2 affects the entire curve, shifting it as a whole along the vertical axis).</li> </ul> <b>!</b> <b>IMPORTANT:</b> <ul style="list-style-type: none"> <li>• The minimum tripping time of the protection is t2. If, according to the calculation, the tripping time is less, it is automatically limited to t2.</li> <li>• For all the UL versions, the maximum time allowed is 0.4 s. If a higher value is set, the trip unit signals the error and forces the parameter to 0.4 s.</li> </ul>

With the modules Ekip T&P or Ekip Bluetooth and with the Ekip Connect software, it is possible to activate the function **Thermal Memory**.

### I Protection

I protection protects against instantaneous short circuit.

When the activation threshold is exceeded, the protection trips within a fixed non-adjustable time.

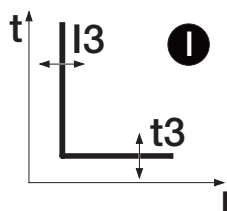

#### Parameters

The user can set the intervention threshold.

Parameter	Description
<b>Enable</b>	By setting the threshold dip-switches to the Off position, the protection is disabled.
<b>Threshold I3</b>	It defines the current value that activates the protection when exceeded (with reference to the curve, it is the part parallel to the y-axis). <b>! IMPORTANT: The I3 threshold set must be higher than the I2 threshold. An incorrect configuration returns an alarm signal.</b>

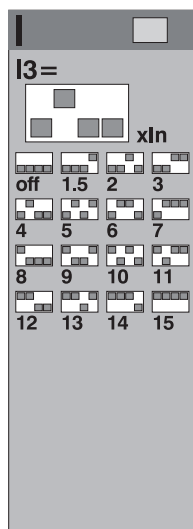



**G Protection** G protection protects against a ground fault.

**NOTE:** the protection is available for the LSIG version of the trip unit.

When the activation threshold is exceeded, the protection trips within a fixed or dynamic time (the time decreases as the current reading increases).

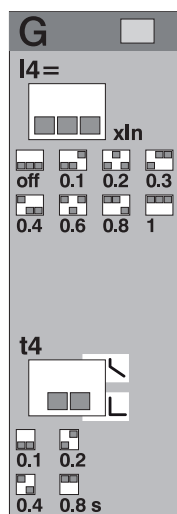
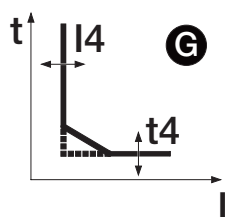

### Parameters

All the parameters that can be modified by the user affect the response curve, and related tripping times.

Parameter	Description
<b>Enable</b>	<p>By setting the dip-switches of the threshold in one of the available combinations other than Off, the protection is enabled.</p> <p>If enabled, the protection is inhibited automatically by the trip unit under two conditions:</p> <ul style="list-style-type: none"> <li>• Disconnection of one or more current sensors.</li> <li>• Current measured on one of the phases higher than a maximum value.</li> </ul> <p><b>IMPORTANT:</b> the maximum current value that deactivates G protection varies according to the threshold set:</p> <ul style="list-style-type: none"> <li>• 8 In (with <math>I4 \geq 0.8 I_n</math>)</li> <li>• 6 In (with <math>0.5 I_n \leq I4 &lt; 0.8 I_n</math>)</li> <li>• 4 In (with <math>0.2 I_n \leq I4 &lt; 0.5 I_n</math>)</li> <li>• 2 In (with <math>I4 &lt; 0.2 I_n</math>)</li> </ul>
<b>Type of curve</b>	<p>It determines the dynamic of the curve and the tripping time, fixed or dynamic according to the selection:</p> <p><b>NOTE:</b> calculation of the tripping time of the inverse time curve is based on a mathematical expression. The details are provided in the table on page 42.</p>
<b>Threshold I4</b>	<p>It defines the current value that activates the protection when exceeded (with reference to the curve, it is the part parallel to the y-axis).</p> <p><b>IMPORTANT:</b></p> <ul style="list-style-type: none"> <li>• The delay is interrupted if the current drops below the tripping threshold.</li> <li>• For all the UL versions the maximum threshold allowed by the trip unit is 1200 A. If a higher value is set, the trip unit signals the error and forces the parameter to 1200 A.</li> </ul>
<b>Time t4</b>	<p>The selected function determines the contribution of t4:</p> <ul style="list-style-type: none"> <li>• Fixed time: t4 is the delay time between the exceeding of the I4 threshold and the sending of the opening command.</li> <li>• Dynamic time: t4 contributes in calculating the tripping time (with reference to the curve, t4 affects the entire curve, shifting it as a whole along the y-axis).</li> </ul> <p><b>IMPORTANT:</b></p> <ul style="list-style-type: none"> <li>• The minimum tripping time of the protection is t4. If, according to the calculation, the tripping time is less, it is automatically limited to t4.</li> <li>• For all the UL versions, the maximum time allowed by the trip unit is 0.4s. If a higher value is set, the trip unit signals the error and forces the parameter to 0.4 s.</li> </ul>

With the Ekip T&P or Ekip Bluetooth modules and with the Ekip Connect software, it is possible to adjust the threshold of **Pre-alarm**.

## Neutral and frequency

Adjusting of the neutral setting is used to customize the L, S and I protections on the Neutral pole with a control factor different from the other phases.



**NOTE:** use the adjustment of the neutral setting only with four-pole or three-pole circuit-breakers with external neutral: with three-pole circuit-breakers and neutral protection active, the trip unit signals the absence of the current sensor.

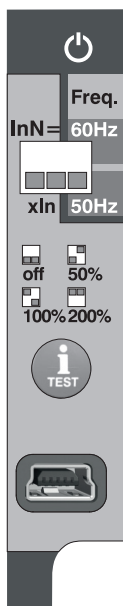

The adjustment of the frequency is used in order to set the installation frequency (between 50 and 60 Hz).

### Neutral parameters

The user can activate the protection and set the percentage for calculation of the protection thresholds.

Parameter	Description
<b>Enable</b>	By setting the threshold dip-switches to the Off position, the protection on the Neutral is disabled.
<b>Threshold InN</b>	It establishes the multiplication factor applied to the trip thresholds of the protections: <ul style="list-style-type: none"> <li>• 50%: trip threshold of the neutral current lower than other phases.</li> <li>• 100%: same trip thresholds for all poles.</li> <li>• 200%: trip threshold of the neutral current higher than other phases.</li> </ul>

### Limitations

The adjustment of the Neutral threshold to value of 200 % must be performed considering the following formula:  $(I_1 * InN) \leq I_u$ .

$I_1$  indicates the threshold of L protection in Amperes (example:  $I_n = 1000$  A;  $I_1 = 0.45 I_n = 450$  A),  $InN$  is the neutral threshold expressed as a multiplication factor (example: 2),  $I_u$  indicates the size of the circuit-breaker (example: 1000 A).



**WARNING! With 200% threshold and measured neutral current exceeding 16In, the Trip unit resets the protection to 100% by itself**

**Additional protections** The Ekip T&P and Ekip Bluetooth modules, and the Ekip Connect software, allow you to set some protections not available via dip-switch:

- Thermal Memory
- T Protection
- Prealarm threshold
- Hardware Trip

#### **Thermal Memory**

This function, available for protections L and S, reduces the tripping time of the protection based on the time elapsed between multiple trips caused by heating of the cables.



**IMPORTANT: for the S protection the function can be activated if the selected curve is time-dependent.**

#### **T Protection**

T protection protects the circuit-breaker against abnormal temperatures recorded by the protection trip unit.

T protection is always active; via Ekip Connect it is possible to enable tripping, which takes place for temperatures  $t < -40\text{ °C}$  or  $t > 85\text{ °C}$ .

#### **Pre-alarm**

The purpose of the pre-alarm, available for L and G protections, is to signal that the measured current is near the activation threshold of the protection itself.

It is possible to set the pre-alarm threshold in order to establish the pre-alarm activation values; the pre-alarm threshold is expressed as a percentage in relation to the protection thresholds (I1 and I4) and is adjustable between 50% and 90% (default value).

*Example: with  $I1 = 0.6 I_n$  and pre-alarm threshold  $L=50\%$ , the pre-alarm is activated for currents greater than  $0.3 I_n$*

The pre-alarm condition is activated for currents higher than the threshold set, and is deactivated for:

- Current less than the pre-alarm threshold.
- Current greater than the activation threshold of protection.

#### **Hardware Trip**

If enabled, the protection activates if one or more disconnections of the current sensors, Rating plug, Trip coil or an alarm inside the unit are detected.

The protection activates with a TRIP if the disconnections persist for more than one second; in the case of Trip coil disconnection, the unit merely handles alarm signaling.

## Summary table of protections

ABB	ANSI <sup>(5)</sup>	Threshold <sup>(1)</sup>	Threshold tolerance <sup>(3)</sup>	Time <sup>(1)</sup>	Calculation formula $t_t$ <sup>(2)</sup>	Calculation example $t_t$ <sup>(2)</sup>	Tolerance $t_t$ <sup>(3)</sup>
<b>L</b>	49	$I1 = 0.4 \dots 1 I_n$	activation for $I_f$ in the range $(1.05 \dots 1.2) \times I1$	$t1 = 3 \dots 144 \text{ s}$	$t_t = (9 t1) / (I_f / I1)^2$	$t_t = 6.75 \text{ s}$ with: $I1 = 0.4 I_n$ ; $t1 = 3 \text{ s}$ ; $I_f = 0.8 I_n$	$\pm 10 \%$ with $I_f \leq 6 I_n$ $\pm 20 \%$ with $I_f > 6 I_n$
<b>S</b> ( $t = k$ )	50 TD	$I2 = 0.6 \dots 10 I_n$	$\pm 7 \%$ with $I_f \leq 6 I_n$ $\pm 10 \%$ with $I_f > 6 I_n$	$t2 = 0.1 \dots 0.8 \text{ s}$	$t_t = t2$	-	The better of the two values: $\pm 10 \%$ or $\pm 40 \text{ ms}$
<b>S</b> ( $t = k / I^2$ )	51	$I2 = 0.6 \dots 10 I_n$	$\pm 7 \%$ with $I_f \leq 6 I_n$ $\pm 10 \%$ with $I_f > 6 I_n$	$t2 = 0.1 \dots 0.8 \text{ s}$	$t_t = (100 t2) / (I_f)^2$	$t_t = 5 \text{ s}$ con: $I2 = 1 I_n$ ; $t2 = 0.8 \text{ s}$ ; $I_f = 4 I_n$	$\pm 15 \%$ with $I_f \leq 6 I_n$ $\pm 20 \%$ with $I_f > 6 I_n$
<b>I</b>	50	$I3 = 1.5 \dots 15 I_n$	$\pm 10 \%$	Not adjustable	$t_t \leq 30 \text{ ms}$	-	-
<b>G</b> ( $t = k$ )	50N TD	$I4^{(4)} = 0.1 \dots 1 I_n$	$\pm 7 \%$	$t4 = 0.1 \dots 0.8 \text{ s}$	$t_t = t4$	-	The better of the two values: $\pm 10 \%$ or $\pm 40 \text{ ms}$
<b>G</b> ( $t = k / I^2$ )	51N	$I4^{(4)} = 0.1 \dots 1 I_n$	$\pm 7 \%$	$t4 = 0.1 \dots 0.8 \text{ s}$	$t_t = 2 / (I_f / I4)^2$	$t_t = 0.32 \text{ s}$ with: $I4 = 0.8 I_n$ ; $t4 = 0.2 \text{ s}$ ; $I_f = 2 I_n$	$\pm 15 \%$
<b>Inst</b>	-	Defined by ABB	-	Instantaneous	-	-	-

<sup>(1)</sup> See the serigraph for the available combinations.

<sup>(2)</sup>  $t_t$  calculation is valid for  $I_f$  values that have exceeded the trip threshold of the protection. Use fault current and threshold values expressed in  $I_n$  to calculate  $t_t$ , as shown in the example.

<sup>(3)</sup> Tolerances valid with trip unit energized in service conditions or with the auxiliary; tripping time  $\geq 100 \text{ ms}$ , temperature and currents within operating limits. If these conditions are not guaranteed, the tolerances in the table shown below apply.

<sup>(4)</sup> In the presence of auxiliary power supply, you can select all the thresholds. In self-supply mode the minimum threshold is limited to:  $0.3 I_n$  (with  $I_n = 100 \text{ A}$ ),  $0.25 I_n$  (with  $I_n = 400 \text{ A}$ ) or  $0.2 I_n$  (for all other sizes).

<sup>(5)</sup> ANSI / IEEE C37-2 encoding.

## Key

- ( $t=k$ ) - Fixed time curve
- ( $t=k/I^2$ ) - Dynamic time curve
- $t_t$  - Tripping time
- $I_f$  - Primary fault current

## Tolerances in particular cases

If the conditions defined in point <sup>(3)</sup> of the above table are not guaranteed, the following tolerances apply:

Protection	Tolerance threshold	Tolerance $t_t$
<b>L</b>	Activation for $I_f$ in the range $(1.05 \dots 1.2) \times I1$	$\pm 20 \%$
<b>S</b>	$\pm 10 \%$	$\pm 20 \%$
<b>I</b>	$\pm 15 \%$	$\leq 60 \text{ ms}$
<b>G</b>	$\pm 15 \%$	$\pm 20 \%$

## 5 - Measurements

**List** Ekip Dip is able to take various measurements, all available via Ekip Connect::

Parameter	Description
<i>Instantaneous currents</i>	Phase current and earth fault measurements in real time
<i>Trip</i>	List of current protection trips (TRIP)
<i>Min Max Measurements</i>	History of minimum and maximum currents, recorded at a settable interval
<i>Operation counters</i>	Number of mechanical and electrical operations

All information is available via the Ekip T&P and Ekip Bluetooth modules and via Ekip Connect software; instantaneous measurements are also available via the Ekip Multimeter unit.

**Instantaneous currents** The instantaneous currents, available in the Measurements pages, are real time measurements of the phase and earth fault currents expressed in root mean square value; the measurement time and performance depend on the rated current defined by the *Rating plug* (In):

Measurement	Monitor time (min-max)	Normal operating range	Accuracy of value read <sup>(1)</sup>
<i>Phase currents</i>	0,004...64 In	0,2...1,2 In	1 %
<i>Internal earth fault currents</i> <sup>(2)</sup>	0,08...64 In	0,2...1,2 In	2 %

<sup>(1)</sup> the accuracies refer to normal operating ranges, as established by IEC 61557-12

<sup>(2)</sup> available with LSIG versions

## 6 - Test

**Presentation** The Ekip TT, Ekip T&P and Ekip Bluetooth modules connected to the Ekip Dip allow you to perform various tests:

- Trip unit LED test
- Check on the presence of the internal battery
- Circuit-breaker opening test (trip test)
- Protection test.

**LED test** The LED test can be performed directly on Ekip Dip:

Phase	Operation
1	Connect a module to the front test connector of frontal test.
2	Press the iTest pushbutton for at least 6 seconds, but less than 9 seconds.
3	When the protection LEDs light up, trip unit the iTest pushbutton.
4	Check the following switch-on sequence: <ul style="list-style-type: none"> <li>• S, I, G LEDs on fixed</li> <li>• Led pre-alarm L and alarm L that alternate three times</li> <li>• All the protection LEDs off</li> </ul>

**Battery test** The battery check is integrated in the LED test procedure, except for the battery error signal:

- If the battery is absent or not working, after iTest is pressed the error is signalled by five flashes of the pre-alarm LED L.
- If the battery is present and working, the LED test proceeds as in the normal procedure.

**Protection test** In order to perform the protection test, follow the instructions below:

Phase	Operation
1	Make sure that the circuit-breaker is closed and that there are no primary currents.
2	Connect Ekip T&P or Ekip Bluetooth to the front test connector.
3	Start the communication with Ekip Connect.
4	Open the Information page and select the Test command, which opens the protection test page.
5	Set up the test as required and verify that the trip unit functions properly.

**Opening test** The opening test can be performed directly on the trip unit or from Ekip Connect.

To perform the test:

Phase	Operation
1	Make sure that the circuit-breaker is closed and that there are no primary currents.
2	Connect a module to the front test connector of frontal test.
3	Press the iTest pushbutton for at least 9 seconds.
4	Check that the circuit-breaker opens and that the TU Reset button comes out

To perform the test from Ekip Connect:

Phase	Operation
1	Make sure that the circuit-breaker is closed and that there are no primary currents.
2	Connect Ekip T&P or Ekip Bluetooth to the front test connector.
3	Start the communication with Ekip Connect.
4	Select the trip test command.
5	Check that the circuit-breaker opens and that the TU Reset button comes out

## 7 - List of alarms and signals

### LED view

Ekip Dip continuously monitors its own operating condition and that of all the devices to which it is connected. All the signals are available with the front LEDs. The protection LEDs provide information with various combinations of lighting and flashing, while the power-on LED, as described on page 34, indicates the power-on conditions of the trip unit.



**NOTE:** *the number of LEDs depends on the version of Ekip Dip (LI, LSI, LSIG).*

### Summary table of LED signals

The following table summarises the signals available with the protection LEDs and the operations to be carried out in response to alarms or fault conditions signalled.

Type of Information	Slow flashing (0.5Hz)			Fast flashing (2 Hz)			On and fixed			2 flashes every 2 s		3 flashes every 3 s	4 flashes every 4 s	HELP	
	All R	G	All R+G	All R	R (single)	G	All R+G	All R	R (single)	G	All R	G	G		G
Internal configuration error <sup>(5)</sup>			x				x	x							A
Trip coil disconnected or trip command failed				x											B
Current sensors disconnected	x														B
Rating Plug error											X				B+E
Protection delay					x										C
Temperature alarm <sup>(1)</sup>					x										C
Pre-alarm L										x					C
Trip <sup>(2)</sup>									x						C
Hardware Trip <sup>(3)</sup>									x	x					B
Installation error						x									E
Parameter error												x			D
Circuit-breaker state not defined or in error		x													B
Error on Local Bus														x	F
Maintenance alarm												x			F
Low battery (during self-test) <sup>(4)</sup>						x									G

<sup>(1)</sup> The temperature alarm is signalled by lighting of the protection L and I red LEDs.

<sup>(2)</sup> The last trip can also be displayed with trip unit off, by pressing the iTest key.

<sup>(3)</sup> The Hardware Trip is signalled by lighting of the pre-alarm L yellow LED and the protection I red led.

<sup>(4)</sup> Five flashes when self-test is started up

<sup>(5)</sup> Error present with one of the three flashing options displayed alongside.

### Key to LED colours

The above table lists the colors of the LEDs, to be interpreted as follows:

- R = red LED (alarm LED L, S, I, G).
- G = yellow LED (pre-alarm LED L).



**NOTE:** *for further details refer to the table listing the components of the interface, available on page 33.*

**HELP**

Some LED signals indicate connection errors or operational errors that require corrective or maintenance operations. The following are the suggestions for checking with reference to the preceding LED table:

<b>HELP note</b>	<b>Operation</b>
A	Contact ABB and give details about the state of the LEDs on the unit.
B	Check the connections between trip unit and accessories (Rating Plug, trip coil, sensors, etc).
C	Normal operation/signalling provided by the trip unit.
D	Error in setting of the dip-switches. Check and correct the following conditions: <ul style="list-style-type: none"> <li>• All the dip-switches of L are in the ON position</li> <li>• <math>I1 \geq I2</math> or <math>I2 \geq I3</math>.</li> <li>• <math>Iu &lt; (2 * In * I1)</math> in the case where <math>InN = 200\%</math>.</li> <li>• <math>I4 &lt; 0.3 In</math> (con <math>In = 100 A</math>), <math>0.25 In</math> (con <math>In = 400 A</math>) or <math>0.2 In</math> (for all other sizes), in the absence of auxiliary power supply.</li> <li>• <math>t2 &gt; 0.4s</math> (in the case of UL circuit-breaker)</li> <li>• <math>t4 &gt; 0.4s</math> (in the case of UL circuit-breaker)</li> <li>• <math>I4 &gt; 1200 A</math> (in case of UL circuit-breaker)</li> </ul>
E	Carry out installation.
F	Connect via Ekip Connect in order to set the Local Bus or to confirm maintenance.
G	Replace the battery.



## 8 - Additional functions

**Additional functions** Ekip T&P, Ekip Programming and Ekip Bluetooth allow the Trip unit to be connected to Ekip Connect software and to access parameters and commands that are not directly available from the front interface; the main ones are:

Name	Description
<i>Maintenance</i>	Function allowing the user to be informed that more than a year has passed since the last maintenance or that contact wear has increased by more than 10%
<i>Local Bus</i>	Bus activation so as to communicate with Ekip Link, Ekip Multimeter or Ekip Signalling 10K modules
<i>Programmable states</i>	Programmable states for monitoring events, to associate with the Ekip Signalling 10K contacts
<i>Programmable Functions</i>	Commands which activate according to the state of signals or events programmable by the user
<i>Led Alive</i>	Configuration of the Power led of the Trip unit and of all modules connected

Details of these and other parameters are given in manual [1SDH001330R1002](#).

## 9 - Default parameters

**Ekip Dip default parameters** The Ekip Dip trip units are supplied with the following default parameters, some adjustable with the front DIPs (protections, Frequency, Neutral), other via front bus.

Protection/Parameter	Value
<b>L</b>	1 In; 144 s
<b>S<sup>(1)</sup></b>	Off; 0.1 s
<b>I</b>	4 In
<b>G<sup>(1)</sup></b>	Off; 0.1 s
<b>Frequency</b>	50 Hz (IEC) / 60 Hz (UL)
<b>Neutral</b>	Off (for three-pole circuit breakers). 50 % (for four-pole circuit-breaker)
<b>Hardware Trip</b>	Disabled
<b>Local Bus</b>	Off
<b>Alive LED</b>	Disabled (Power-on LED fixed)
<b>Maintenance</b>	Off

<sup>(1)</sup> S Protection available with LSI and LSIG versions of the trip unit. G Protection available with LSIG version.

# Accessories

## 1 - Overview

**Overview and connection** Emax 2 circuit-breakers have a set of electronic, electrical and mechanical accessories, the availability of which depends on the CB model.

Consult manual 1SDH001330R1002 for details, circuit diagrams 1SDM000091R0001 and assembly instructions for the connection.

**Electronic accessories** Electronic accessories for Ekip Dip:

Name	Mounting	Function
<i>Rating Plug</i> <sup>(1)</sup>	Front	Defines rated current In
<i>Ekip Supply</i>	Terminal box	Power supply of Trip unit and modules in terminal box
<i>Ekip Link</i> <sup>(2)</sup>	Terminal box	Communication between Trip units via an intranet with ABB proprietary protocol

Other external modules and accessories:

Name	Function
Ekip Signalling 10K	Programmable digital inputs/outputs
Ekip Multimeter	Panel front display
External neutral	Sensor for protecting the external neutral line with 3P circuit-breaker

In addition, the supervision, configuration and reporting functions are provided by further modules for temporary communication and supply:

Name	Function
<i>Ekip TT</i>	Supply and tests
<i>Ekip T&amp;P</i>	Supply, communication, programming and tests
<i>Ekip Programming</i>	Supply, communication and programming
<i>Ekip Bluetooth Key</i>	Bluetooth communication and programming

<sup>(1)</sup> assembled by default at the time of order; can be replaced afterwards with a model of a different size

<sup>(2)</sup> always supplied for contacts Ekip AUP and Ekip RTC

**Mechanical accessories** Electrical and mechanical accessories for E2.2-E4.2-E6.2:

Type of accessory	Accessory	Circuit-breakers	Switch-disconnectors
Electrical signalling	AUX 4Q	S	R
	AUX 6Q	R	R
	AUX 15Q <sup>(5)</sup>	R	R
	Ekip AUP <sup>(1)</sup>	R	R
	Ekip RTC	R	R
	S51	S	-
	S51/2 <sup>(6)</sup>	R	-
Electrical control	S33 M/2	R	R
	YO <sup>(4)</sup> - YC	R	R
	YO2 <sup>(4)</sup> - YC2	R	R
	YU <sup>(2)(4)</sup>	R	R
	YU2 <sup>(2)(4)</sup>	R	R
	M	R	R
Security mechanical	YR	R	-
	KLC - PLC	R	R
	KLP - PLP <sup>(1)</sup>	R	R
	SL <sup>(1)</sup>	S	S
	DLR <sup>(1)</sup>	R	R
	DLP <sup>(1)</sup>	R	R
	DLC <sup>(5)</sup>	R	R
	Anti-insertion lock	S	S
MOC	R	R	
Protection mechanical	FAIL SAFE <sup>(3)</sup>	R	R
	PBC	R	R
Interlocks	IP54	R	R
	MI <sup>(5)</sup>	R	R

S: Standard. R: on request.

<sup>(1)</sup> For withdrawable version only.

<sup>(2)</sup> Incompatible with FAIL SAFE. Can be ordered for UL on request

<sup>(3)</sup> Incompatible with YU; standard for UL version.

<sup>(4)</sup> A maximum of two accessories are available for YO and YU.

<sup>(5)</sup> Not available for withdrawable circuit-breakers with lateral fastening.

<sup>(6)</sup> Incompatible with YR

## 2 - Rating Plug

### Description

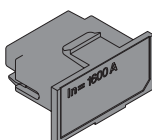

The *Rating Plug*, supplied with Ekip Touch, establishes the rated current  $I_n$  required by the measuring range and sets the current protections (with reference to  $I_n$ ).

It is installed on a dedicated front connector and is accessible to the user for inspections or replacement following a change of model/size.

For further details about the available models, operations and reference documents, consult document [1SDH001330R1002](#).

# Putting into service and maintenance

## 1 - Putting into service

**Introduction** The general check is necessary:

- when the circuit-breaker is put into service for the first time
- after prolonged inactivity of the circuit-breaker



**HAZARD! RISK OF ELECTRIC SHOCK! Test the circuit-breaker with all switchgear apparatus de-energized.**



**IMPORTANT: The checks involve carrying out procedures that can be performed only by Skilled Persons in the electrical field (IEV 195-04-01: person with relevant education and experience to enable him or her to perceive risks and to avoid hazards which electricity can create).**

**General checks** Before putting it into service for the first time or after a prolonged period of inactivity, some checks must be carried out on the circuit-breaker and the environment in which it is installed:

Points to be checked	Checks
<b>Switchgear</b>	1. Sufficient change of air to avoid overtemperatures
	2. Clean location, free of all installation refuse (e.g.: cables, tools, metal splinters)
	3. Circuit-breaker mounted correctly (tightening torques, clearances respected)
	4. The installation environmental conditions must be consistent with the "Environmental conditions" specifications on page 23
<b>Connections</b>	1. Power connections tightened to the terminals of the circuit-breaker
	2. Busbars with adequate cross-section
	3. Correct ground connections
	4. Maximum distances of separators respected
<b>Operations</b>	Perform some opening and closing operations (See chapter "Description of the product - circuit-breaker opening/closing operations on page 16). The spring loading lever must move with regularly  <b>WARNING! in the presence of an undervoltage coil the circuit-breaker can be closed only after the trip unit is energized</b>
<b>Trip unit alarm</b>	Connect the protection device Ekip TT to the trip unit and verify that there are no alarms present
<b>State of the circuit-breaker with Ekip Dip</b>	With Ekip Dip, the circuit-breaker state must not be in error (see table on page 45). Perform a circuit-breaker closing/opening operation and make sure that there are no alarms (see table on page 45)
<b>State of the circuit-breaker with Ekip Touch</b>	With Ekip Touch, the circuit-breaker state must be read correctly (see table on page 45). Perform a circuit-breaker closing/opening operation and make sure that change of state is read correctly
<b>Trip Test</b>	With circuit-breaker closed and in conditions of rest (without circulating currents), carry out a Trip test, and verify the opening of the circuit-breaker
<b>Ekip Dip parameters</b>	Check and modify the protection dip switches, presence of external neutral and frequency to suit your installation requirements
<b>Ekip Touch parameters</b>	Connect the Ekip TT device. Check and make the necessary changes to: protection parameters, circuit-breaker configuration, frequency, password, date and language





**NOTE:** for safety reasons, ABB strongly advises you to change the password right from the first access and to keep it with care.

**Wizard** When powered, the Ekip Touch shows the Wizard window, a user-friendly procedure for immediate adjustment of certain parameters: language, date, time, voltage of the installation (if Ekip Measuring is present) and password.

After the procedure has terminated, the window will no longer appear unless it is reset by Ekip Connect (Reset Wizard command): in this case, it will appear the first time the apparatus is powered after the command has been sent.

**Check accessories** The following procedures for checking the accessories are to be performed before they are put into service:

Accessories <sup>(*)</sup> to be checked	Procedure
Gearmotor	1. Power the gearmotor to charge the springs at the relevant rated voltage.
	Result: The springs are charged correctly. The signals are normal. When the springs are charged the gearmotor stops.
	2. Perform some closing and opening operations.
	Result: The gearmotor recharges the springs after every closing operation.
	 <b>NOTE:</b> <i>If present, power the undervoltage coil in advance.</i>
Undervoltage coil	1. Power the undervoltage coil at the relevant rated voltage and perform the closing operation on the circuit-breaker.
	Result: The circuit-breaker closes correctly; the signals are normal.
	2. Turn off the voltage supply to the trip unit. The circuit-breaker opens.
	3. Power the undervoltage coil at the relevant rated voltage and perform the closing operation on the circuit-breaker.
	Result: The circuit-breaker closes; the signal switches over.
	 <b>WARNING!</b> <b>If the undervoltage coil has been tripped by a power failure, the circuit-breaker can be closed only after the coil has been energized electrically. Make sure that the coil has effectively been tripped due to a power failure. Otherwise, examine the circuit-breaker and the associated equipment to make sure that they are in a good condition.</b>
Opening coil	1. Close the circuit-breaker.
	2. Power the opening coil at the relevant rated voltage.
	Result: The circuit-breaker opens correctly; the signals are normal.
Closing coil	1. Open the circuit-breaker.
	2. Charge the springs manually or electrically.
	3. Power the closing coil at its rated voltage.
	Result: The circuit-breaker closes correctly; the signals are normal.
Opening coil with Ekip Com Actuator	1. Power the protection trip unit with the Vaux auxiliary power supply.
	2. Power the Ekip Com Actuator contacts.
	3. Close the circuit-breaker
	4. Select <b>“open CB”</b> from the Ekip Touch menu
	Result: The circuit-breaker opens correctly; the signals are normal.
	 <b>NOTE:</b> <i>The test can be performed if the trip unit and the coils are energized.</i>

(\*) if present.

(\*\*) withdrawable versions only.

Continued on the next page

Accessories <sup>(*)</sup> to be checked	Procedure
Closing coil with Ekip Com Actuator	1. Power the protection trip unit with the Vaux auxiliary power supply.
	2. Power the Ekip Com Actuator contacts.
	3. Charge the springs.
	4. Select <b>"close CB"</b> from the Ekip Touch menu
	Result: The circuit-breaker closes correctly; the signals are normal.
	 <b>NOTE:</b> The test can be performed if the protection trip unit and the coils are energized.
Lock for circuit-breaker in open position (key or padlock)	1. Open the circuit-breaker
	2. Keep the opening pushbutton pressed
	3. Turn the key and remove it
	4. Attempt the circuit-breaker closing operation.
	Result: Both manual and electrical closing is prevented.
Auxiliary open/closed contacts of the circuit-breaker	1. Connect the auxiliary contacts to appropriate signalling circuits or to the multimeter.
	2. perform some closing and opening operations on the circuit-breaker.
	Result: signalling occurs normally.
Circuit-breaker connected, isolated for test, disconnected auxiliary contacts	1. Connect the auxiliary contacts to appropriate signalling circuits.
	2. bring the circuit-breaker to the connected, isolated for test and disconnected position.
	Result: the signals due to the relative operations are normal.
Locking devices for connected/test/disconnected positions <sup>(**)</sup>	1. Perform operating tests.
	Result: the interlocks function correctly.
Interlocks between circuit breakers assembled side by side and stacked	1. Perform operating tests.
	Result: the interlocks function correctly.
Racking-in/out device <sup>(**)</sup>	1. Perform a few racking-in and racking-out operations.
	Result: in the rack-in operation the circuit-breaker is connected correctly. There is no particular resistance during the first turns of the handle.
Auxiliary accessories and auxiliary voltage	Verify the proper installation. The supply voltage of the auxiliary accessories must be between 85% and 110% of the rated voltage for the auxiliary accessories.
External modules	1. For all modules with terminal box: check connection to <i>Ekip Supply</i> in mechanical seat of terminal box For <i>Ekip Signalling 10K</i> and <i>Ekip Multimeter</i> : check connection of the bus of module (W3-W4) to the respective sockets of <i>Ekip supply</i> or terminal box
	2. Power up the Trip unit (and external modules if there is a separate supply) and make sure they are on
	3. Check on menu or via Ekip Connect that the local bus on the Trip unit is enabled
	4. Check that the Power LED on each module is on in the same way as the Power LED of Ekip Touch (steady or synchronous flash)
	5. Check on menu or via Ekip Connect to make sure that all installed modules are present and that there are no alarms
External neutral, single-pole sensor (SGR), residual current sensor (Rc)	1. Make sure that the sensor is connected to the terminal box
	2. Power up the Trip unit and make sure it is on
	3. For <i>External neutral</i> : check in the <i>Settings - Circuit-breaker</i> menu that <i>Configuration= 3P + N</i> ; otherwise change the parameter For single-pole and residual current sensors: set presence and size in the <i>Settings - Circuit-breaker - Earth protection</i> menu; protection parameters in the <i>Protections</i> or <i>Advanced</i> menus
	4. Make sure there are no alarms

(\*) if present.

(\*\*) withdrawable versions only.

Accessories <sup>(*)</sup> to be checked	Procedure	ABB   SACE Emax 2
Zone selectivity	1. Check selectivity connections (between Ekip Touch and the other units) as shown in circuit diagrams	
	2. Provide Ekip Touch with auxiliary power and make sure that CB status is: Open	
	3. Check that the protection of the selectivity concerned has been enabled (example: S protection)	
	4. Select the <i>Test - Zone Selectivity</i> menu and the submenu of the protection concerned; repeat points 5, 6, 7 and 8 for each protection activated	
	 <b>NOTE:</b> for selectivity D, consider submenu S for the Forward connections and G for the Backward connections	
	Check <b>Output:</b>	
	5. Select the <i>Force Output</i> command and check, on the unit connected to the Ekip Touch output, that the state of its <i>Input</i> = <b>ON</b>	
	6. Select <i>Release Output</i> and check on the unit that <i>Input</i> = <b>OFF</b>	
Check <b>Input:</b>		
7. Select the <i>Force Output</i> command in the unit connected to the Ekip Touch input; check on Trip unit: <i>Input</i> = <b>ON</b>		
8. Select <i>Release Output</i> and check on Trip unit: <i>Input</i> = <b>OFF</b>		

**Final check list** Perform the operations described below after having completed the general inspection procedures and checked the accessories. Print this sheet and use it to make an inspection report in the "Checks" column.

Operation	Description	Check
1	Circuit-breaker OFF	Open the circuit-breaker
2	Circuit-breaker connected	Switch the circuit-breaker in withdrawable version to the connected position and reposition the crank in its seat
3	Trip unit Parameters	Adjust the protection trip unit in accordance with the design specifications of the installation (drawn up by design engineer of the installation). If necessary, power the protection trip unit with an Ekip TT unit
4	Removal of the Ekip TT	If present, remove the Ekip TT unit
5	Connecting the voltage	Connect the auxiliary voltage
6	Closing the switchgear	Close the switchgear door
7	Charging the springs	Charge the closing springs
8	Undervoltage coil	Make sure that undervoltage coil is energized
9	Opening and closing coils	Make sure that opening and closing coils are NOT energized
10	Mechanical interlock of the circuit-breaker	If present, make sure that the mechanical interlock of the circuit-breaker is not active
11	Locking devices	If present, make sure that the locking devices of the circuit-breaker are not active
12	Status signals	Make sure that the signalling devices on the front of the circuit-breaker indicate: circuit-breaker open - springs discharged O - OPEN and white spring signalling device DISCHARGED SPRING

---

## 2 - Identification of alarms or failures

---

**Introduction** The protection trip unit is able to identify some faults and to signal them through LEDs or display; you need to identify the cause and eliminate it before re-closing the circuit-breaker, both locally and remotely.



**WARNING! detecting faults must only be managed by persons skilled in electrical matters (IEV 195-04-01): person with sufficient training and experience to enable him or her to perceive risks and to avoid the dangers potentially created by electricity)**  
**This is because it may be necessary to perform insulation and dielectric tests on part or all of the installation.**

Some failures involve partial operation of the circuit-breaker. Consult the paragraphs "Faults, causes and remedies" where the possible causes of the main faults are listed.

Further information on the Ekip Touch and on the accessories mentioned in this chapter and which are not covered in this manual are available on the website <http://www.abb.com/abblibrary/DownloadCenter/>, with the Ekip Touch manual [1SDH001316R0002](#).

---



## Faults, causes and remedies

The following is a list of possible fault situations, their possible causes and suggestions for resolving them.



**NOTE:** with *Ekip Touch*, also make use of the suggestions given in document [1SDH001316R1002](#).

Faults	Possible causes	Suggestions
The circuit-breaker doesn't close when the closing pushbutton is pressed	The trip signal of the protection trip unit has not been reset	Press the TU mechanical reset pushbutton or operate the electrical reset remotely.
	The open-position key lock or padlock is activated	Unlock the lock in open position using the relevant key
	The circuit-breaker is in an intermediate position between connected and isolated for test or between isolated for test and disconnected	Complete the rack-in operation
	The undervoltage coil is not energized	Check the power supply circuit and the power supply voltage
	The opening coil is permanently energized	Correct operating condition.
	The trip unit pushbutton is pressed (withdrawable version)	Rotate the crank to complete
The circuit-breaker doesn't close when the closing coil is powered	The trip signal of the protection trip unit has not been reset	Press the TU Reset button
	The power supply voltage of the auxiliary circuits is too low	Measure the voltage: it should not be lower than 70% of the rated voltage of the coil
	The power supply voltage is different from that indicated on the rating plate	Check the voltage on the rating plate
	The cables of the coil are not inserted correctly in the terminals	Make sure there is continuity between cable and terminal and if necessary reconnect the cables of the coil to the terminals
	The connections in the power supply circuit are wrong	Check the connections using the relevant wiring diagram
	The closing coil is damaged	Replace the coil
	The operating mechanism is blocked	Perform the closing operation manually; if the fault persists contact ABB
	The open position key lock is activated	Unlock the lock in open position using the relevant key
	The circuit-breaker is in an intermediate position between connected and test or the trip unit pushbutton is pressed (withdrawable version)	Complete the rack-in operation
	The undervoltage coil is not energized	Make sure that undervoltage coil is energized properly
The circuit-breaker doesn't open when the opening pushbutton is pressed	The opening coil is permanently energized	Correct operating condition. If necessary, disconnect the power from the opening coil
	The racking out crank handle is inserted (withdrawable version)	Remove the crank
	The operating mechanism is blocked	Contact ABB

Continued on the next page

<b>Faults</b>	<b>Possible causes</b>	<b>Suggestions</b>
The circuit-breaker doesn't open when the opening coil is powered	The operating mechanism is blocked	Contact ABB
	The power supply voltage of the auxiliary circuits is too low	Measure the voltage: it should not be lower than 85 % of the rated voltage of the coil
	The power supply voltage is different from that indicated on the rating plate	Use the correct voltage
	The cables of the coil are not inserted correctly in the terminals	Make sure there is continuity between cable and terminal and if necessary reconnect the cables of the coil to the terminals
	The connections of the power supply circuit are wrong	Check the connections using the relevant wiring diagram
	The opening coil is damaged	Replace the coil
The circuit-breaker doesn't open despite the command of the undervoltage coil	The operating mechanism is blocked	Perform the opening operation manually; if the fault persists contact ABB
It is not possible to charge the closing springs by means of the manual charging lever	The operating mechanism is blocked	Contact ABB
It is not possible to charge the closing springs by means of the gearmotor	The cables of the gearmotor are not inserted correctly in the terminals	Make sure there is continuity between cable and terminal and if necessary reconnect the cables of the gearmotor to the terminals
	The connections of the power supply circuit are wrong	Check the connections using the relevant wiring diagram
	The circuit-breaker is in disconnected position	Switch the circuit-breaker to the test or connected position
	The gearmotor protection internal fuse has tripped	Replace the fuse
	The gearmotor is damaged	Replace the gearmotor
It is not possible to press the button in order to insert the racking out crank handle	The circuit-breaker is closed	Press the opening pushbutton in order to allow the insertion of the crank with the circuit-breaker open
It is not possible to insert the moving part in the fixed part	The racking-in/racking-out operation is not performed correctly	See chapters "Circuit breaker racking-in/racking-out operations" on pages 18
	The moving part is incompatible with the fixed part	Check the compatibility between the moving part and the fixed part
It is not possible to lock the circuit-breaker in the open position	The opening pushbutton is not being pressed	Press the opening pushbutton and activate the lock
	The lock in open position is defective	Contact ABB
It is not possible to perform the trip test	The opening solenoid is not inserted correctly	Check connection of opening solenoid and check leds
	The trip signal of the protection trip unit has not been reset	Press the reset pushbutton
	The busbar current is greater than zero	Correct operating condition.

Continued on the next page

<b>Faults</b>	<b>Possible causes</b>	<b>Suggestions</b>
It is not possible to remove the circuit-breaker from the disconnected position	Fail Safe lock active	Discharge the closing springs of the command
Tripping times shorter than expected	Selected threshold too low	Modify the threshold
	Wrong curve selected	Modify the curve
	Thermal memory enabled	Disable it if it is not necessary
	Incorrect neutral selection	Modify the neutral selection
	Zone Selectivity enabled	Disable it if it is not necessary
Tripping times longer than expected	Threshold too high	Modify the threshold
	Curve too high	Modify the curve
	Wrong curve selected	Modify the curve type
	Incorrect neutral selection	Modify the neutral selection
Rapid trip with I3 = Off	Inst trip	Correct operating condition with short circuit at high current
High ground-fault current, but no trip occurs	Function G inhibited owing to high current	Correct operating condition (see use cases in the chapter that describes the protection)
Incorrect current reading	Current below the minimum threshold that can be displayed	Correct operating condition.
The expected trip does not occur	Trip excluded	Correct operating condition. Enable trip if necessary

## 3 - Maintenance

**Safety standards** The following are the warnings to be respected during the maintenance operations



**HAZARD! RISK OF ELECTRIC SHOCK! Risk of electric shock or accident.**



**WARNING! before proceeding with any maintenance operation, it is mandatory to:**

- **Set the circuit-breaker to the open position and make sure that the springs of the operating mechanism are discharged.**
- **In the case of a withdrawable circuit-breaker, extract the circuit-breaker from the fixed part (see the indication DISCONNECTED)**
- **If work must be performed on fixed circuit-breakers or on fixed parts, disconnect the power supply to the power circuit and auxiliary circuits and visibly ground the terminals on both the supply side and load side.**
- **Use adequate personal protection equipment, ensure that the apparatus is in a safe condition and proceed in accordance with the Laws in force.**

**Skilled personnel** The maintenance operations must be carried out by Skilled Personnel:

electrically skilled person (IEV 195-04-01): person with relevant education and experience to enable him or her to perceive risks and to avoid hazards which electricity can create.

ABB declines all liability for damage to persons or property caused by failure to comply with the instructions in this document.

**Circuit-breaker life** The circuit-breakers SACE Emax 2, with or without opening or closing coils, can withstand the following operating cycles if regularly serviced. For further information see chapter 4 - Environmental conditions on page 23.

circuit-breaker IEC 60947	Interrupted rated current  I <sub>u</sub> (40°C) [A]	Mechanical life with regular maintenance		Electrical life				Frequency of operations/hour
				440V AC	690V AC	900V AC	1150V AC	
				No. of operations (x 1000)				
E2.2	< 1250	No. of operations (x 1000)	Frequency of operations/hour	15	15	2	1	30
	1600	25	60	12	10	2	1	30
	2000	25	60	10	8	2	1	30
	2500	20	60	8	7	2	1	30
E4.2	< 2500	20	60	10	10	0,5	1	20 <sup>(1)</sup>
	2500	20	60	8	8	0,5	1	20 <sup>(1)</sup>
	3200	20	60	7	7	0,5	1	20 <sup>(1)</sup>
	4000	15	60	5	4	0,5	1	20 <sup>(1)</sup>
E6.2	4000	12	60	4	4	1	1	10
	5000	12	60	3	2	1	1	10
	6300	12	60	2	2	1	1	10

<sup>(1)</sup> Only for 900V and 1150V circuit-breakers Operating sequences/hour = 10.

Continued on the next page

circuit-breaker UL 1066	Interrupted rated current  I <sub>u</sub> (40°C) [A]	Mechanical life with regular maintenance		Electrical life		
		No. of operations (x 1000)	Frequency of operations/ hour	508V AC No. of operations (x 1000)	635V AC No. of operations (x 1000)	Frequency of operations/ hour
E2.2-A	< 1600	25	60	15	15	30
	1600	25	60	12	10	30
	2000	25	60	10	8	30
E4.2-A	< 2500	20	60	10	10	20
	2500	20	60	8	8	20
	3200	20	60	7	7	20
E6.2-A	4000	12	60	4	4	10
	5000	12	60	3	2	10
	6000	12	60	2	2	10

**Maintenance schedule** Proper maintenance of the equipment allows good electromechanical operation to be maintained over time. The maintenance plan for SACE Emax 2 circuit-breakers specifies two periodic levels of maintenance for the different types of site conditions.

The following is a table of maintenance frequency with the periodic intervals and the routine maintenance operations.

Type of maintenance	Frequency of maintenance in standard environments <sup>(1)</sup>	Frequency of maintenance in dusty environments (dust level measured > 1mg/m <sup>3</sup> )
First Level	One year or 20% of mechanical life or 20% of electrical life	6 months or 10% of mechanical life or 10% of electrical life
Second Level	Three years or 50% of mechanical life or 50% of electrical life or after a trip due to short-circuit	18 months or 25% of mechanical life or 25% of electrical life or after a trip due to short-circuit

<sup>(1)</sup> Only for 900V and 1150V circuit-breakers Operating sequences/hour = 10.

Compliance with the following rules is also recommended:

- Even circuit-breakers that operate infrequently or that remain closed or open for long periods of time must be subjected to programmed maintenance.
- All the circuit-breakers provide information on the number of operations performed in the presence of auxiliary power supply of the Trip Unit. With Ekip Dip trip units, the information can be obtained with the aid of Ekip T&P and a PC on which the Ekip Connect software is installed. With Ekip Touch trip units, the information is available at any time on the appropriate display. With Ekip Dip trip units, installation of the mechanical operation counter is recommended (supplied on request).
- During the service, visually inspect the circuit-breaker from the outside to check for the presence of dust, dirt or damage.

## 4 - First level maintenance

First level maintenance should be carried out in accordance with the maintenance schedule shown on page 58.

### Preliminary operations



**WARNING! before proceeding with any maintenance operation, it is mandatory to:**

- **Set the circuit-breaker to the open position and make sure that the springs of the operating mechanism are discharged.**
- **In the case of a withdrawable circuit-breaker, extract the circuit-breaker from the fixed part (see the indication DISCONNECTED)**
- **If work must be performed on fixed circuit-breakers or on fixed parts, disconnect the power supply to the power circuit and auxiliary circuits and visibly ground the terminals on both the supply side and load side.**

### Inspections and general cleaning

Perform the following checks:

1. Make sure that the circuit-breaker is clean. Remove dust and oily substances or excess grease with a clean, dry cloth and mild detergent if necessary. If there is a thick build-up of dirt, use a thinner from the greasing kit or ask for assistance from the service staff.
2. Check that the rating plates with the technical specifications of the apparatus are present.
3. Clean the rating plates with clean, dry rags.
4. Make sure that there are no foreign bodies in the circuit-breaker compartment.

### Circuit-breaker connections and connections between circuit-breaker and switchboard

Perform the following checks on the connections:

1. With dry paint-brushes and rags remove dust or soil, if present (use a non- aggressive detergent if necessary. Use a cleaning product such as Henkel 273471 or Chemma 18 or equivalent if there is a heavy coating of dirt).
2. Make sure there are no traces of overheating on the terminals. Overheating is detected by a different coloration of the parts in contact; the contact parts are usually silvery white in colour.
3. Check the tightness of fastening bolts for all connections to the terminals



**WARNING! if work must be performed on fixed circuit-breakers or on fixed parts, disconnect the power supply to the power circuit and auxiliary circuits and visibly ground the terminals on both the supply side and load side.**

## Disassembly operations

To disassemble the parts of the circuit-breaker:

1. Remove the transparent flange (A) of the trip unit, by turning the screws (B).
2. Remove the front cover of the circuit-breaker (C), by removing the mounting screws (D).

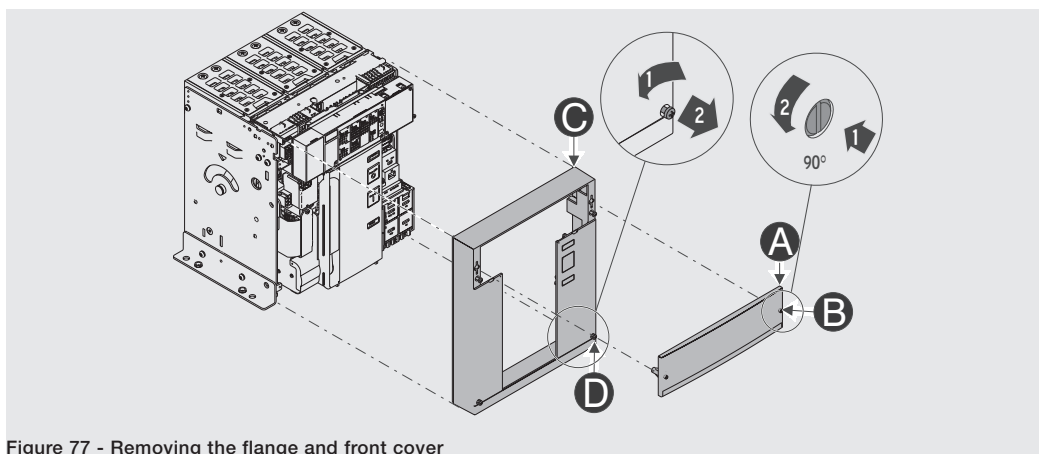

Figure 77 - Removing the flange and front cover

3. Remove the gearmotor (E) by removing the screw (F) and the connector.

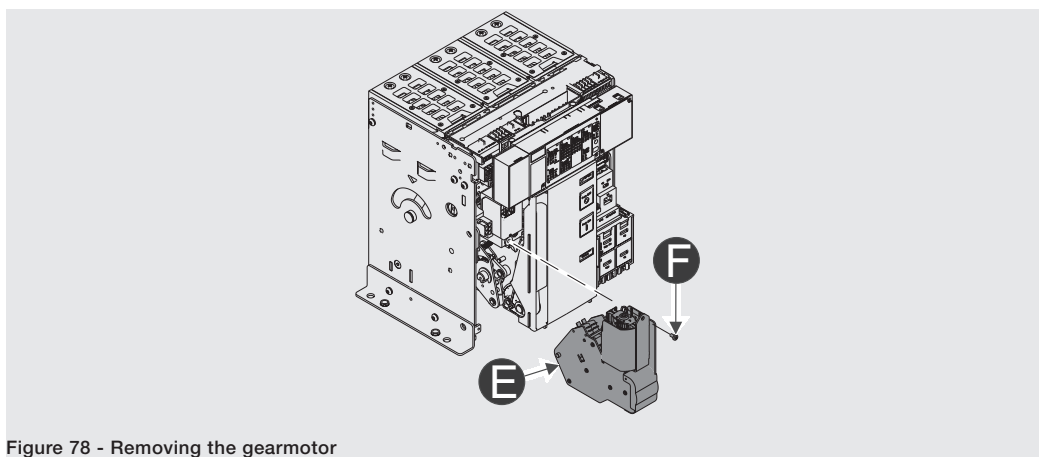

Figure 78 - Removing the gearmotor

4. If there is an undervoltage coil (G), remove it, and discharge the springs of the operating mechanism for closing and opening the circuit breaker.

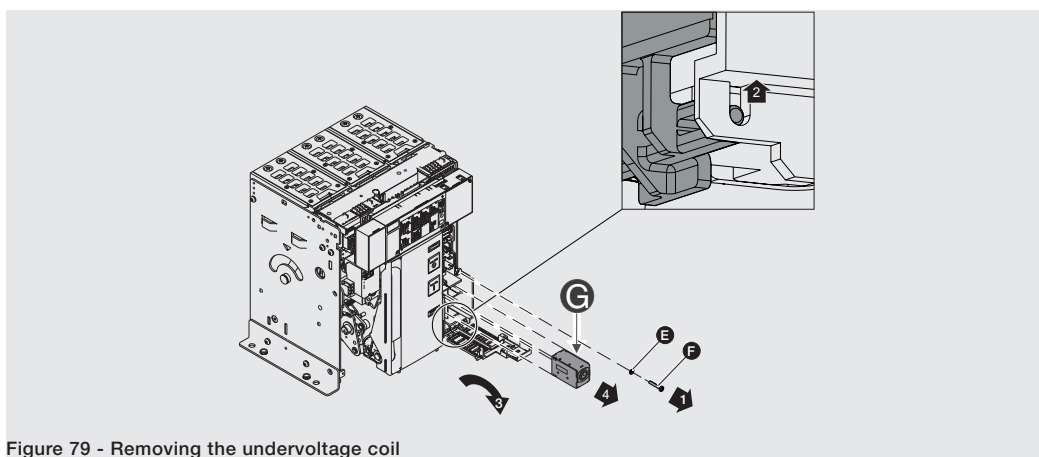

Figure 79 - Removing the undervoltage coil

## Cleaning and lubrication of the operating mechanism

To clean and lubricate:

1. Clean the closing shaft and closing hook at the point indicated. In the case of excessive deposits you can use a laminate thinner such as Henkel 273471 or Chemma 18 or equivalent.
2. Lubricate, in the points indicated, the closing shaft and closing hook with grease Mobilgrease 28 (EXXON MOBIL).
3. Make sure that the closing shaft is free to rotate.

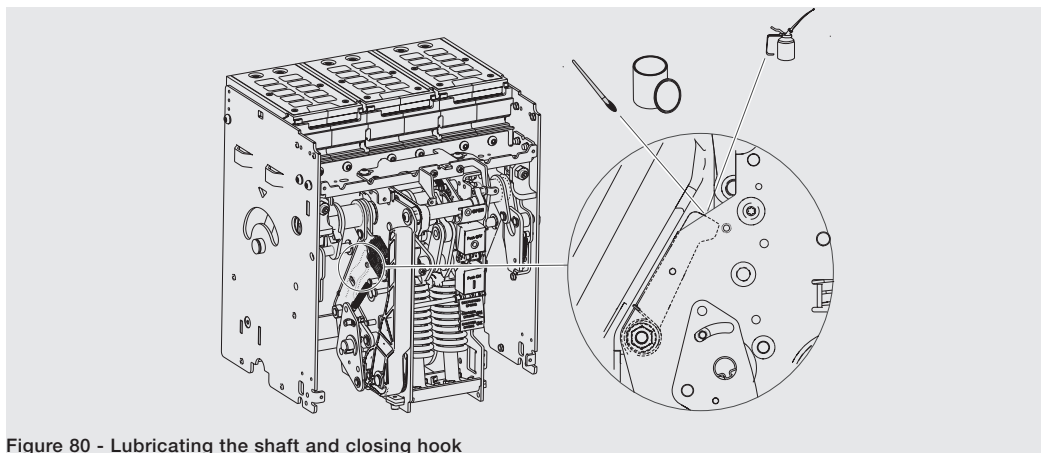

Figure 80 - Lubricating the shaft and closing hook

## Inspection of electrical and mechanical accessories

Check the accessories:

1. Check that the accessories are securely fixed to the circuit-breaker.
2. Check that the accessories are connected correctly to the circuit-breaker.
3. Make sure that the coils (YU-YO-YC), if present, are in good condition (no excessive wear and tear, overheating, rupture).
4. Make sure that the mechanical operation counter functions correctly (if present) by operating the circuit-breaker.
5. Check the wear on the brushes of the gearmotor and if necessary replace them.



**NOTE:** it is advisable to replace the gear motor if it has performed more than 10000 spring charging operations or reached 50% of the declared mechanical life of the circuit-breaker.

## Inspection of the protection trip unit

Check that the trip unit is in good condition:

1. Power the protection trip unit with an Ekip TT battery unit.
2. Check the correct operation of the protection trip unit: tripping test with "Trip Test" and "Autotest".
3. With a Ekip Dip verify the absence of alarms through frontal LEDs.
4. With a Ekip Touch, verify the absence of alarms via the display and the front LEDs.
5. Make sure that the cables are correctly connected to the modules and to the trip unit (if applicable).
6. On a Ekip Touch check the percentage of wear on the contacts of the circuit-breaker.
7. Finally, remove the Ekip TT battery unit.

## Test with Ekip Connect

Test the trip unit:

1. Connect the Ekip Bluetooth or Ekip T & P unit to the trip unit.
2. Connect the computer where the program is installed by means of a Bluetooth or USB connection.
3. After connecting the computer and trip unit, check that there are no alarm signals. Otherwise, refer to the paragraph " 2 - Identification of alarms or failures" on page 54.
4. In the absence of alarms you can proceed to the trip test and self test (depending on the type of trip unit). For future checks it is recommended to insert the current date in the area called "Information". These data will be stored within the trip unit itself.
5. Remove the Ekip Bluetooth or Ekip T & P unit from the trip unit.



**Final checks** Reassemble and check the circuit-breaker:

1. Reassemble all the parts by performing all the operations indicated in the paragraph "Disassembly Operations" in reverse order and, if necessary, reconnect the auxiliary power supply.
2. Put the movable part (breakers) in the test position (see indication TEST).
3. Perform the following operations 10 times:
  - *Opening (in both local and remote modes, if applicable)*
  - *Closing (in both local and remote modes, if applicable)*
  - *Tripping via Trip Test*
4. Perform the operations in the following sequence:
  - *Open - Springs discharged*
  - *Open - Springs charged*
  - *Closed - Springs discharged*
  - *Closed - Springs charged*
5. Check that the following operate correctly:
  - *accessories, if provided.*
  - *garmotor, if provided.*
  - *undervoltage coil, if provided.*
  - *opening coil, if provided.*
  - *closing coil, if provided.*
  - *auxiliary contacts of the circuit-breaker, if provided.*
  - *lock for circuit-breaker in open position (key or padlock), if provided*

**Interlock check** Check that the vertical or horizontal interlocking devices (if provided) are installed and that they operate correctly.



**WARNING! the interlocks cannot be tested in the Test or Disconnected positions.**

Perform maintenance periodically as indicated in the table below.

Activity	Frequency	Maintenance operations
Functionality	1 year or	See kit sheet
Check tightness	20% of mechanical life or	
Lubrication	20% of electrical life	As shown in the figure
Cables	Three years or 50% of the mechanical life or 50% of the electrical life of the largest circuit-breaker involved in the interlock. After a trip due to a short-circuit.	Replacement is advisable

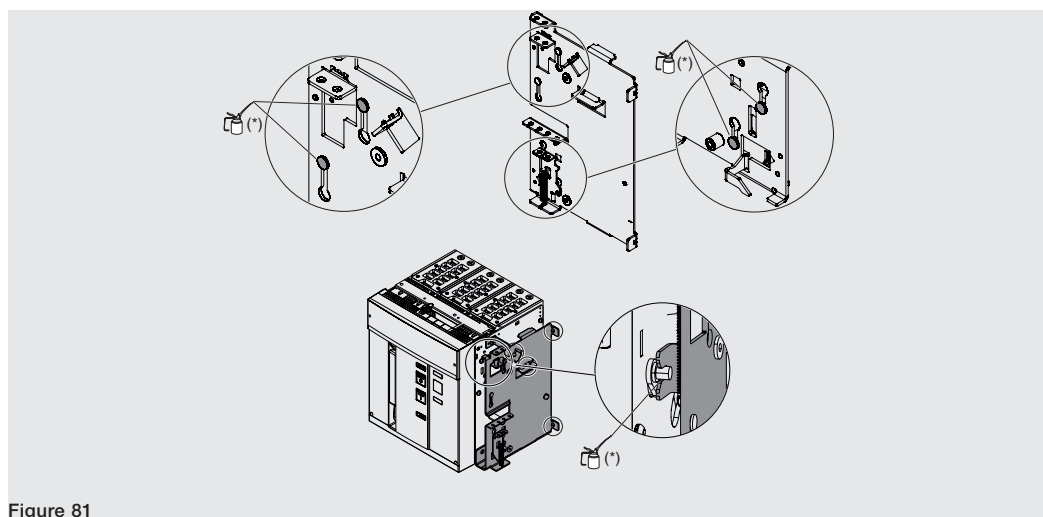

Figure 81

(†) Use Mobilgrease 28, also available in the ABB greasing kit.

## 5 - Second level maintenance

The second level maintenance must be performed in accordance with the maintenance schedule shown on page 58.

### Preliminary operations



**WARNING! before proceeding with any maintenance operation, it is mandatory to:**

- **Set the circuit-breaker to the open position and make sure that the springs of the operating mechanism are discharged.**
- **In the case of a withdrawable circuit-breaker work with it withdrawn from the fixed part. For removal of the fixed part see paragraph "Circuit breaker racking-in/racking-out operations" on page 18 .**

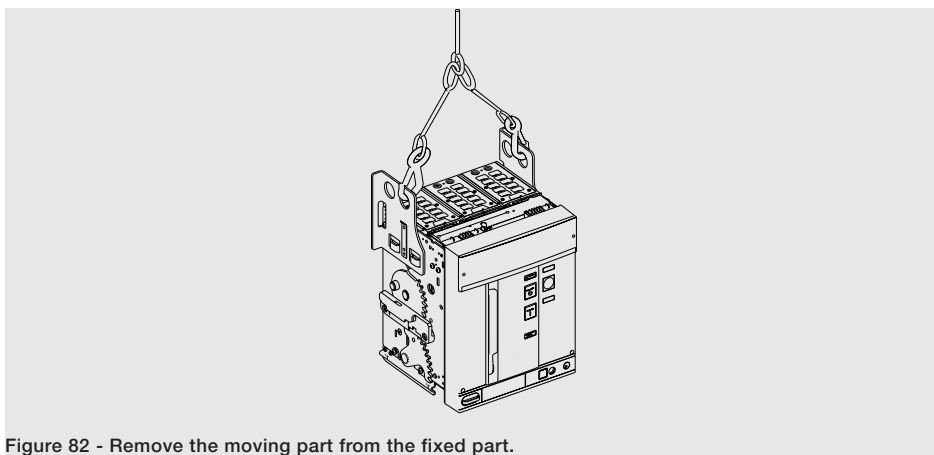

Figure 82 - Remove the moving part from the fixed part.

- **If work must be performed on fixed circuit-breakers or on fixed parts, disconnect the power supply to the power circuit and auxiliary circuits and visibly ground the terminals on both the supply side and load side.**

### Inspections and general cleaning

Perform the following checks:

1. Make sure that the circuit-breaker is clean. Remove dust and oily substances or excess grease with a clean, dry cloth (use a mild detergent if necessary. If there is a thick build-up of dirt, use a thinner from the greasing kit or ask for assistance from the service staff).
2. Check that the rating plates with the technical specifications of the apparatus are present.
3. Clean the rating plates with clean, dry rags.
4. If the circuit-breaker is in the withdrawable version, remove all traces of dust, mould, condensation and oxidation inside the fixed part.
5. Make sure that there are no traces of overheating or cracks, which could impair the insulating parts of the circuit-breaker
6. Check the integrity of the separation pliers (for withdrawable circuit-breaker).
7. The jaw contacts must be silvery in colour with no traces of erosion or discoloration.
8. Make sure that there are no foreign bodies in the circuit-breaker compartment.
9. Make sure that the screws that fasten the fixed part to the switchgear are well tightened (M8 - 25Nm - 221.27 lb in)

**Circuit-breaker connections and connections between circuit-breaker and switchboard**

---

Perform the following checks on the connections:

1. Remove any dust or dirt with a brush and dry cloth (use a mild detergent if necessary. If there is a thick build-up of dirt, use a thinner from the greasing kit or ask for assistance from the service staff).
2. Make sure there are no traces of overheating on the terminals. Overheating is detected by a different coloration of the parts in contact; the contact parts are usually silvery white in colour.
3. Make sure that the bolts of the terminal connections are well tightened.



**WARNING! if work must be performed on fixed circuit-breakers or on fixed parts, disconnect the power supply to the power circuit and auxiliary circuits and visibly ground the terminals on both the supply side and load side.**

---

## Disassembly operations

To disassemble the parts of the circuit-breaker:

1. Remove the transparent flange (A) of the trip unit, by turning the screws (B).
2. Remove the front cover of the circuit-breaker (C), by removing the mounting screws (D).

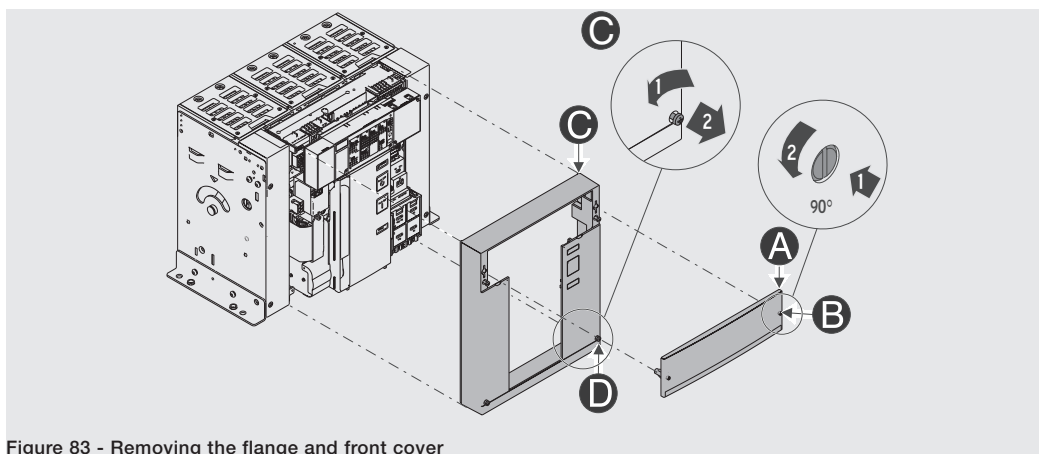

Figure 83 - Removing the flange and front cover

3. Remove one or both of the side guards (I) (if installed) by removing the front screws (L).
4. Remove the gearmotor (E) by removing the screw (F) and the connector.

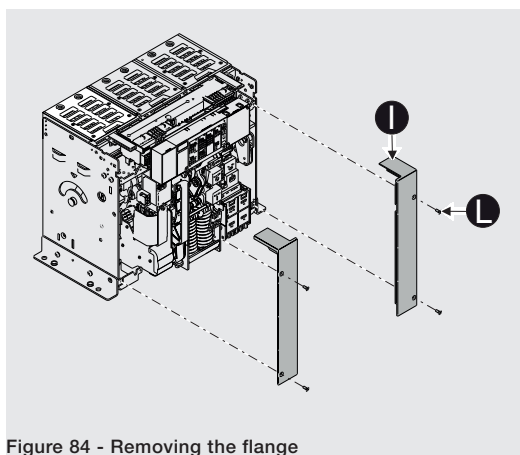

Figure 84 - Removing the flange

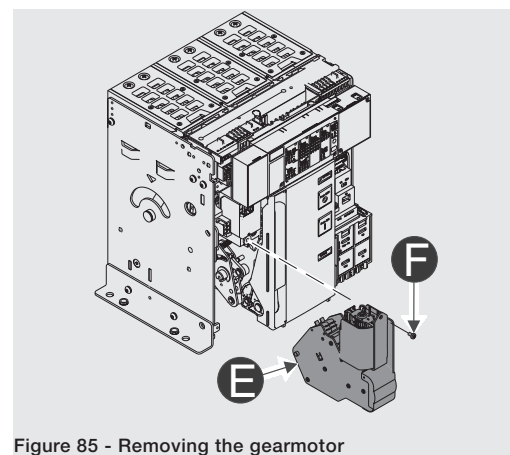

Figure 85 - Removing the gearmotor

5. If there is an undervoltage coil (G), remove it, and discharge the springs of the operating mechanism for closing and opening the circuit breaker.

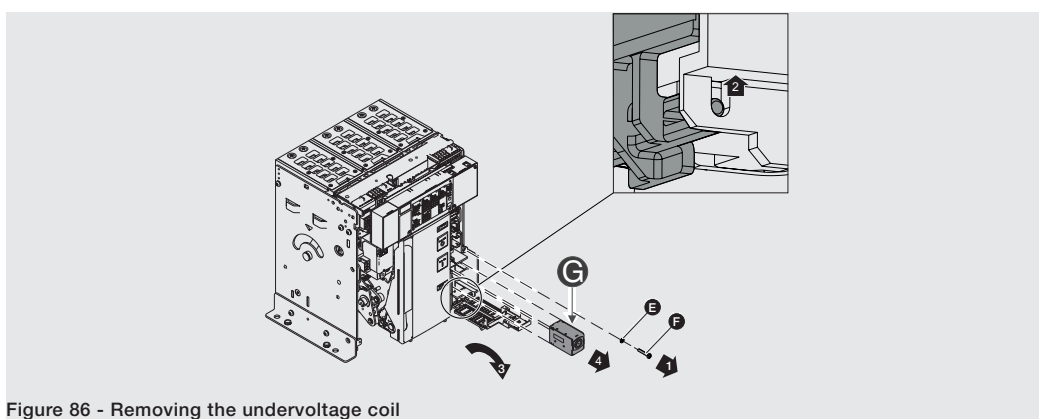

Figure 86 - Removing the undervoltage coil

Continued on the next page

- Remove the front cover of the circuit-breaker (e) by removing the screws (f) and the protection plate (g) by removing the screw (h).

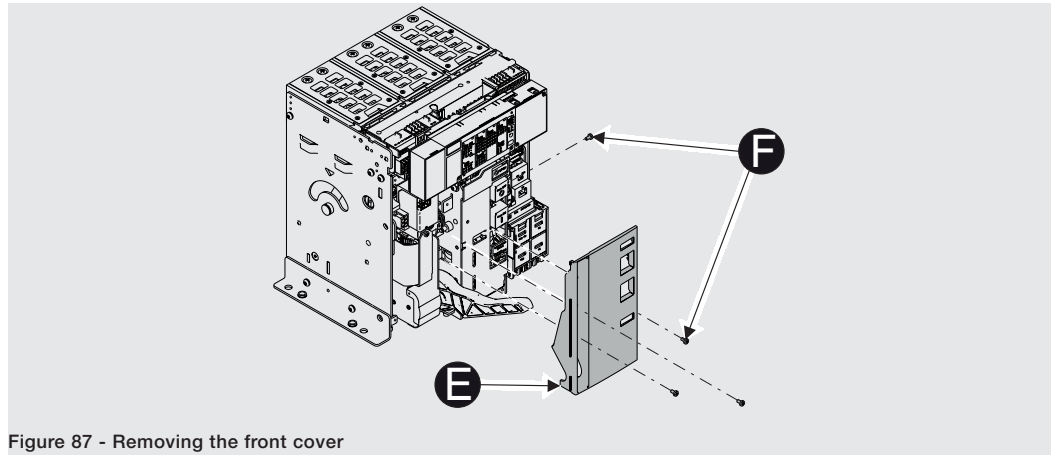

Figure 87 - Removing the front cover

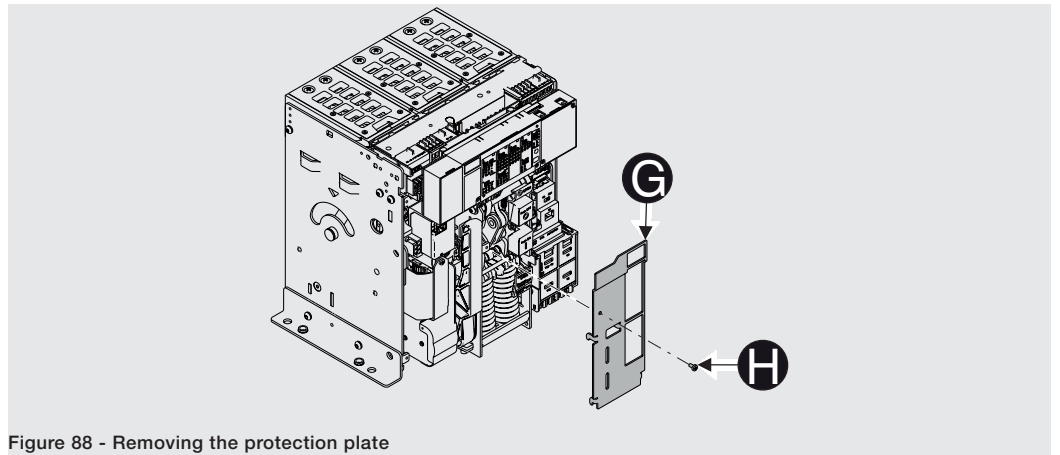

Figure 88 - Removing the protection plate

Before cleaning and lubrication of the operating mechanism, you must remove the protection trip unit. For information about removal, see the document [1SDH001000R0523](#), or request the intervention of a technician ABB.

## Cleaning and lubrication of the operating mechanism

To clean and lubricate:

1. Clean the closing clip, the closing rod and opening rod in the points shown in the illustrations. If there is a thick build-up of dirt, use a thinner from the greasing kit or ask for assistance from the service staff.
2. Lubricate closing hook, the closing shaft, opening hook and opening shaft in the points indicated by the illustrations with Mobilgrease 28 grease (EXXON MOBIL).
3. Make sure that the opening and closing shafts are free to turn.

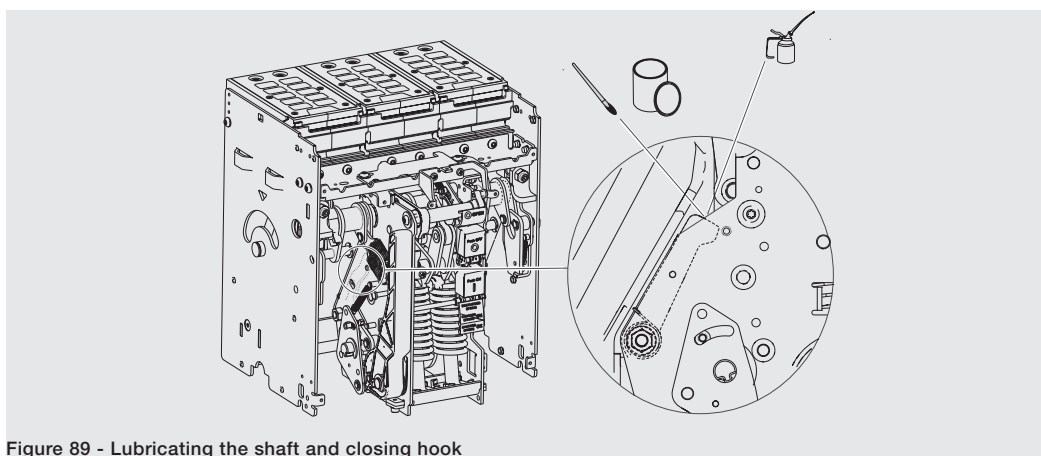

Figure 89 - Lubricating the shaft and closing hook

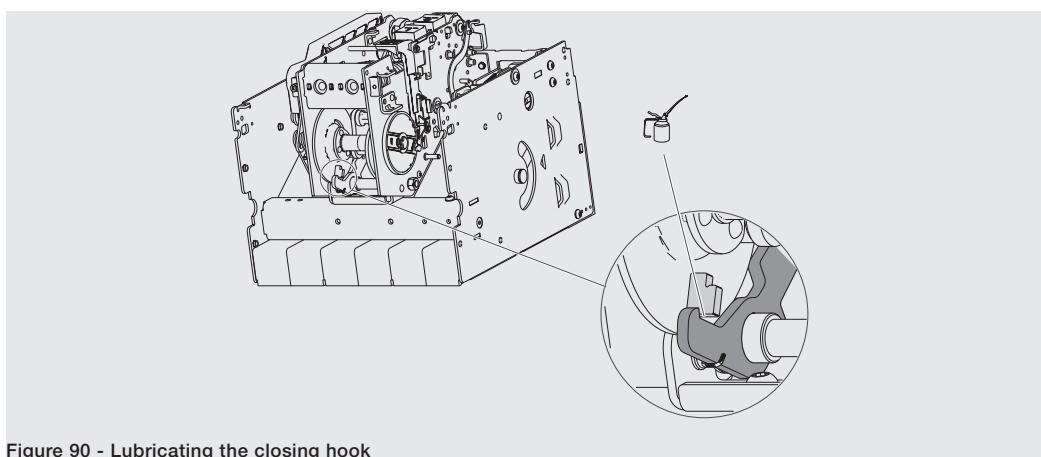

Figure 90 - Lubricating the closing hook

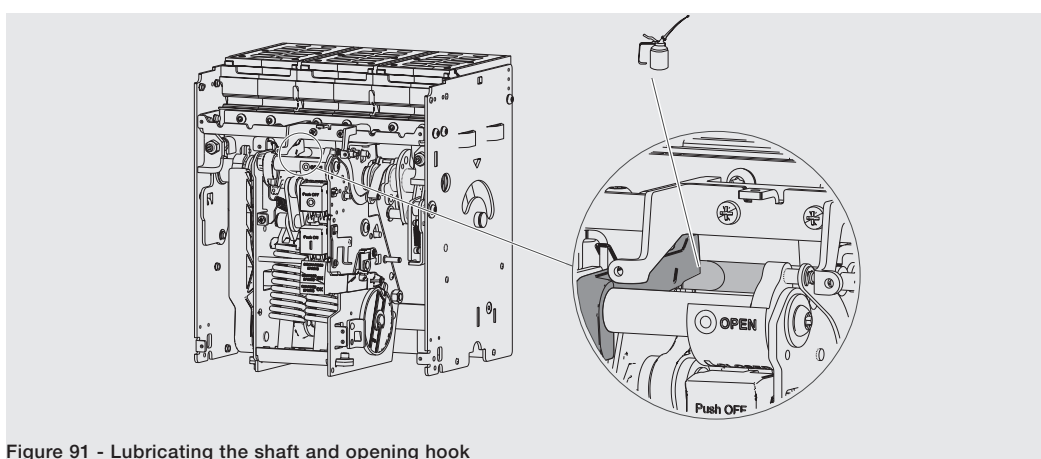

Figure 91 - Lubricating the shaft and opening hook

Continued on the next page

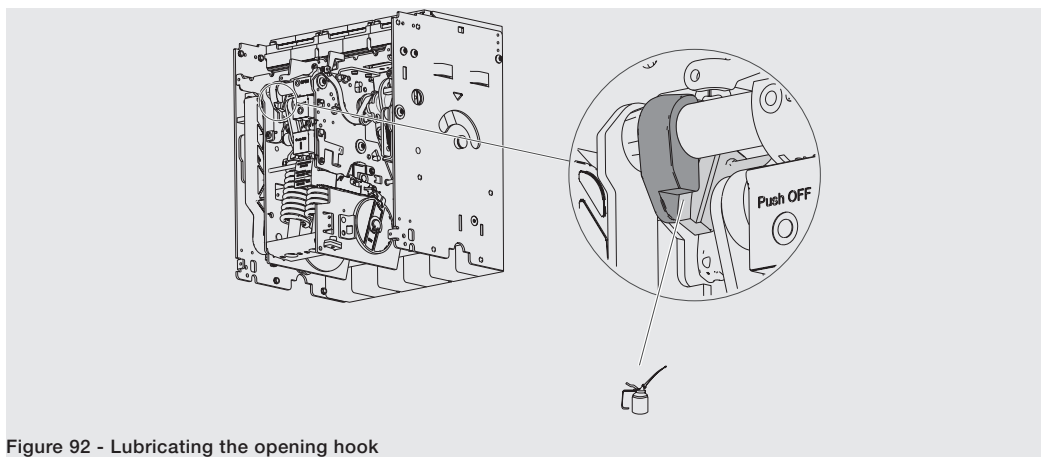

Figure 92 - Lubricating the opening hook

- In the case of deformed or rusty springs, rings missing or severe wear of the operating device, contact ABB Sace.

### Inspection of electrical and mechanical accessories

Check the accessories:

1. Check that the accessories are securely fixed to the circuit-breaker.
2. Check that the accessories are connected correctly to the circuit-breaker.
3. Make sure that the coils (YU-YO-YC) are in good condition (no excessive wear and tear, overheating, rupture).
4. Make sure that the mechanical operation counter functions correctly (if present) by operating the circuit-breaker.
5. Check the wear on the brushes of the gearmotor and if necessary replace them.



**NOTE:** *it is advisable to replace the gear motor if it has performed more than 10000 spring charging operations or reached 50% of the declared mechanical life of the circuit-breaker.*

**Check for wear on the contacts** With the circuit-breaker open and springs discharged:

1. Remove the arc chutes

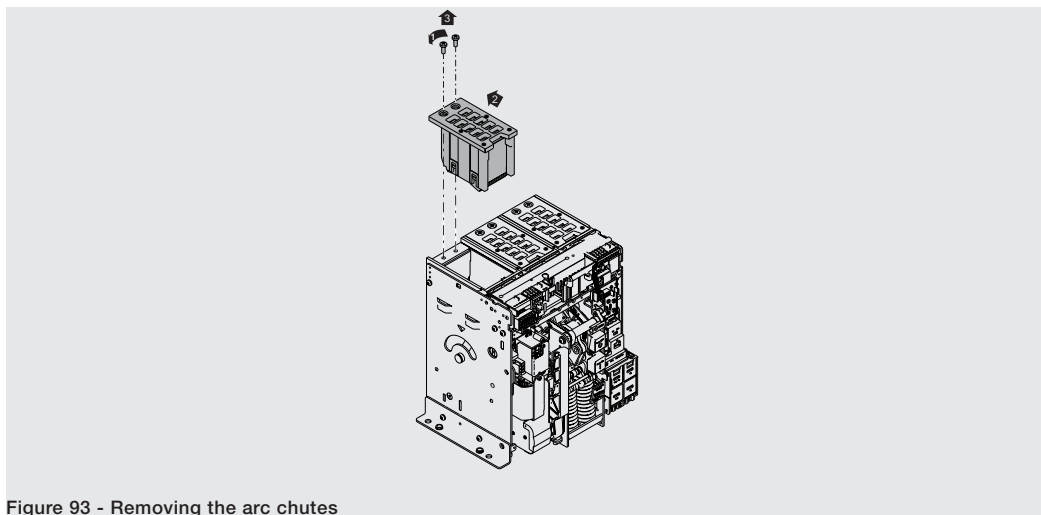

Figure 93 - Removing the arc chutes

2. Check the condition of the arc-breaking chutes: the base of the chute must be undamaged and the plates must be neither corroded nor indented.
3. Remove the dust with compressed air, then clean off all traces of fumes and slags with a brush.
4. Make sure that the contacts are in good condition.
5. Visually check to make sure that the main and arc-breaking plates are in place.
6. Check for tarnishing or beading. If such defects are discovered, ask for assistance from a qualified ABB Technician (\*).
7. Check the arc-breaking gaps (distance A).

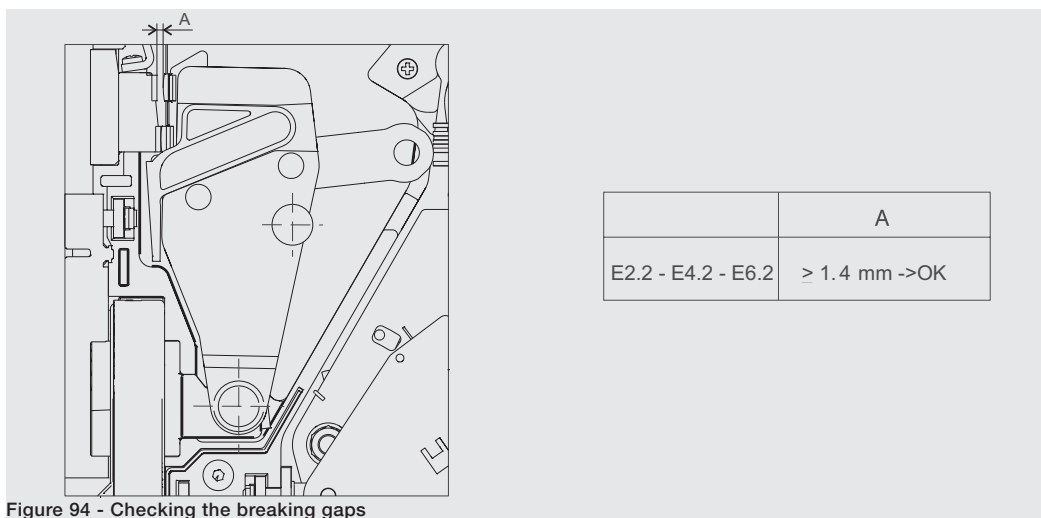

Figure 94 - Checking the breaking gaps

8. Close the circuit-breaker and check dimension A. Contact ABB Sace (\*) if dimension A is incorrect. If dimension A is correct, open the circuit-breaker again and re-assemble the arc chutes.



**NOTE:** (\*) After approval from the customer, ABB can proceed with replacement of the worn parts.



## Inspection of the protection trip unit

Check that the trip unit is in good condition:

1. Power the protection trip unit with an Ekip TT battery unit.
2. Check the correct operation of the protection trip unit: tripping test with "Trip Test" and "Autotest".
3. With Ekip Dip release, check front leds to make sure there are no alarms.
4. With Ekip Touch release, check display and front leds to make sure there are no alarms.
5. Make sure that the cables are correctly connected to the modules and to the trip unit (if applicable).
6. Check percentage of wear on circuit-breaker contacts on Ekip Touch release.
7. Finally, remove the Ekip TT battery unit.

## Test with Ekip Connect

Test the trip unit:

1. Connect the Ekip Bluetooth or Ekip T & P unit to the trip unit.
2. Connect the computer where the program is installed by means of a Bluetooth or USB connection.
3. After having connected computer and release, check that there are no alarm signals from release. If there are, consult section " 2 - Identification of alarms or failures" on page 54.
4. In the absence of alarms you can proceed to the trip test and self test (depending on the type of trip unit). For future checks it is recommended to insert the current date in the area called "Information". These data will be stored within the trip unit itself.
5. Remove the Ekip Bluetooth or Ekip T & P unit from the trip unit.

## Final checks

Reassemble and check the circuit-breaker:

1. Reassemble all the parts by performing all the operations indicated in the paragraph "Disassembly Operations" in reverse order and, if necessary, reconnect the auxiliary power supply.
2. Put the movable part (breakers) in the test position (see indication TEST).
3. Perform the following operations 10 times:
  - *Opening (in both local and remote modes, if applicable)*
  - *Closing (in both local and remote modes, if applicable)*
  - *Tripping via Trip Test*
4. Perform the operations in the following sequence:
  - *Open - Springs discharged*
  - *Open - Springs charged*
  - *Closed - Springs discharged*
  - *Closed - Springs charged*
5. Check that the following operate correctly:
  - *accessories, if provided.*
  - *gearmotor, if provided.*
  - *undervoltage coil, if provided.*
  - *opening coil, if provided.*
  - *closing coil, if provided.*
  - *auxiliary contacts of the circuit-breaker, if provided.*
  - *lock for circuit-breaker in open position (key or padlock), if provided*

**Interlock check** Check that the vertical or horizontal interlocking devices (if provided) are installed and that they operate correctly.



**WARNING! the interlocks cannot be tested in the Test or Disconnected positions.**

Perform maintenance periodically as indicated in the table below.

Activity	Frequency	Maintenance operations
Functionality	1 year or	See kit sheet As shown in the figure
Check tightness	20% of mechanical life or	
Lubrication	20% of electrical life	
Cables	Three years or 50% of the mechanical life or 50% of the electrical life of the largest circuit-breaker involved in the interlock. After a trip due to a short-circuit.	Replacement is advisable

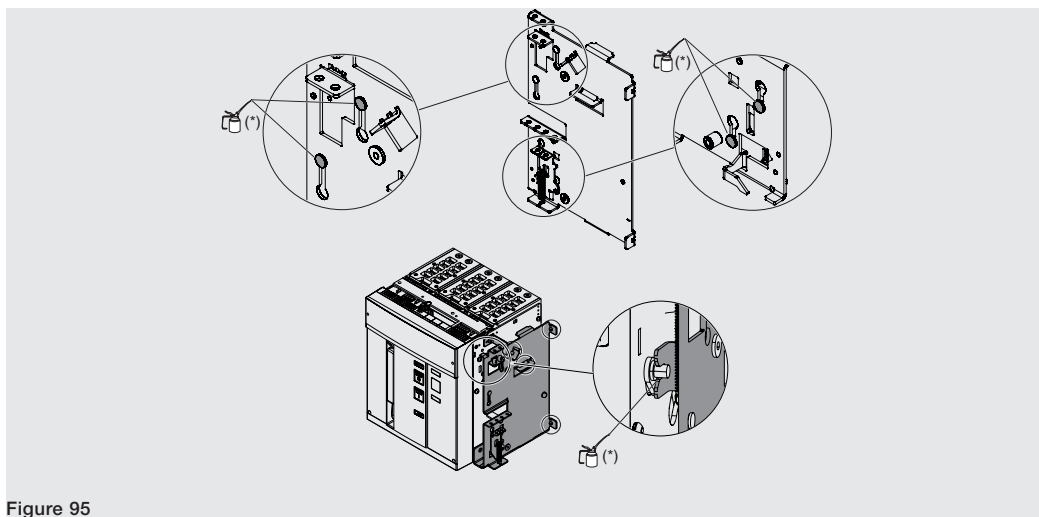

Figure 95

<sup>(1)</sup> Use Mobilgrease 28, also available in the ABB greasing kit.

## 6 - Decommissioning and treatment at end of life

**Safety standards** During the early stages of the process of decommissioning and end of life treatment of SACE Emax 2 circuit-breakers, observe the following safety rules:

- the closing springs, even if discharged, must never to be taken apart
- for handling and lifting of the circuit-breakers refer to the section "Unpacking and handling" on page 10 .



**HAZARD! RISK OF ELECTRIC SHOCK! Unplug or disconnect any power supply, to avoid any potential risk of shock during removal of the circuit-breaker from the service.**



**WARNING! After dismantling the switchgear, the circuit-breaker must be stored in the open position with the closing springs discharged and with the front cover mounted.**

**Trained personnel** The operations for decommissioning SACE Emax 2 circuit-breakers involve performing procedures that can be performed by Trained Persons in the electrical field (IEV 195-04-02: person adequately advised or supervised by electrically skilled persons to enable him or her to perceive risks and to avoid danger which electricity can create).

**End of life treatment for circuit-breaker materials** The materials used in the production of SACE Emax 2 circuit-breakers are recyclable and should be treated separately as shown in the following table:

TYPE	MATERIAL
A	Plastic parts <sup>(1)</sup>
B	Metal parts
C	Printed circuits
D	Current sensors, cables, motors, electrical windings

<sup>(1)</sup> All the components of significant dimensions bear a mark specifying the type of material.



**NOTE:** refer to the national legislation in force at the time of decommissioning of the product, in the case where it specifies end of life treatment procedures different from those indicated.

**Disposal of packing materials** The materials used for the packaging of SACE Emax 2 circuit-breakers are recyclable and should be treated separately as shown in the following table:

TYPE	MATERIAL
A	Plastic parts
B	Cardboard parts
C	Wooden parts
D	Metal parts



**NOTE:** refer to the national legislation in force at the time of decommissioning of the product, in the case where it specifies end of life treatment procedures different from those indicated.





1SDH001000R0002 - ECN000109166 - Rev. D